

SY-2 Service Manual Contents

	Page
Specification	1
Coding Guide	2
Technical Information	3~18
Assembly Layout, Top View & Back view	19
Block Diagram	20
SM1 Circuit Diagram	21
SM1 Circuit Board & Wiring	22
SM2 Circuit Diagram	23
SM2 Circuit Board & Wiring	24
SK Circuit Diagram	25
SK Circuit Board & Wiring	26
SP1 Circuit Board & Wiring	27
SP1 Terminal Voltage Table	28
SP1 Circuit Board & Wiring	29
SP2 Circuit Diagram	30
SP2 Terminal Voltage Table	31
SP2 Circuit Board & Wiring	32
Power Supply Circuit Diagram	33
Panel 1 Circuit Diagram (1),(3)	34
Panel 1 Circuit Diagram (2)	35
Panel 2, 3, & 4 Circuit Diagram	36
Manual Keyboard Switch Circuit Diagram	37
New Parts Specification	38~39
Overall Circuit Diagram	40
Parts List	

SY-2 Specifications

KEYBOARD 37 keys C₂ ~ C₅

PRESET TONE LEVERS

Side I

Flute
Trombone
Trumpet
Saxophone
Oboe
Bow Violin
Piano
Harpsichord
Contrabass
Tuba
Bass Guitar
Funny
Trumute
Double

Side II

Clarinet
Bassoon
French Horn
Bass Clarinet
English Horn
Pizzicato String
Guitar
Hawaiian Guitar
Pizzicato Bass
Sousaphone
Wah Guitar
Drake
Growl
Reed

Side I/Side II Selector

FILTER CONTROLS

Preset/Control Selector
Low Pass Frequency
Low Pass Resonance
High Pass Frequency
High Pass Resonance

ENVELOPE CONTROLS

Preset/Control Selector
Attack Time
Decay Time
Sustain Level
Release Time

VIBRATO CONTROLS

Preset/Control Selector
Speed
Depth

TRANSPOSITION LEVERS

One Octave Down
Normal
One Octave Up
Two Octaves Up

TOUCH CONTROLS

Vibrato Depth(On/Off)
Wah-Wah(On/Off)
Volume(On/Off)
Sensitivity

FOOT CONTROLS

Wah-Wah(On/Off)
Volume(On/Off)
Sensitivity

TONE BEND CONTROLS

Preset/Control Selector
Attack Time
Intensity
Decay Time

PITCH BEND CONTROL

On/Off Selector

PORTAMENTO CONTROLS

On/Off Selector
Time

PULSE WIDTH CONTROLS

Preset/Control Selector
Width

OTHER CONTROLS

Tune
Master Volume

OTHER FITTINGS

Outputs
Phone Jack
Pin Jack
Level Switch(High/Low)
Foot Controller Jack
Power Switch
Pilot Lamp
Music Rest

CIRCUITRY

Solid State
Power Consumption: 20 Watts
Power Source: AC, 50/60Hz

DIMENSIONS

Width: 90cm (35½")
Depth: 32cm (12½")
Height: 17cm (6¾") without legs
20cm (8") with case

WEIGHT 21kg (46 lbs.)

FINISH Black Leatherette Siding

ATTACHMENT Foot Pedal

Coding Guide

WIRING FOR EXPLANATION PURPOSES.

DF CIRCUIT BOARD AND WIRING

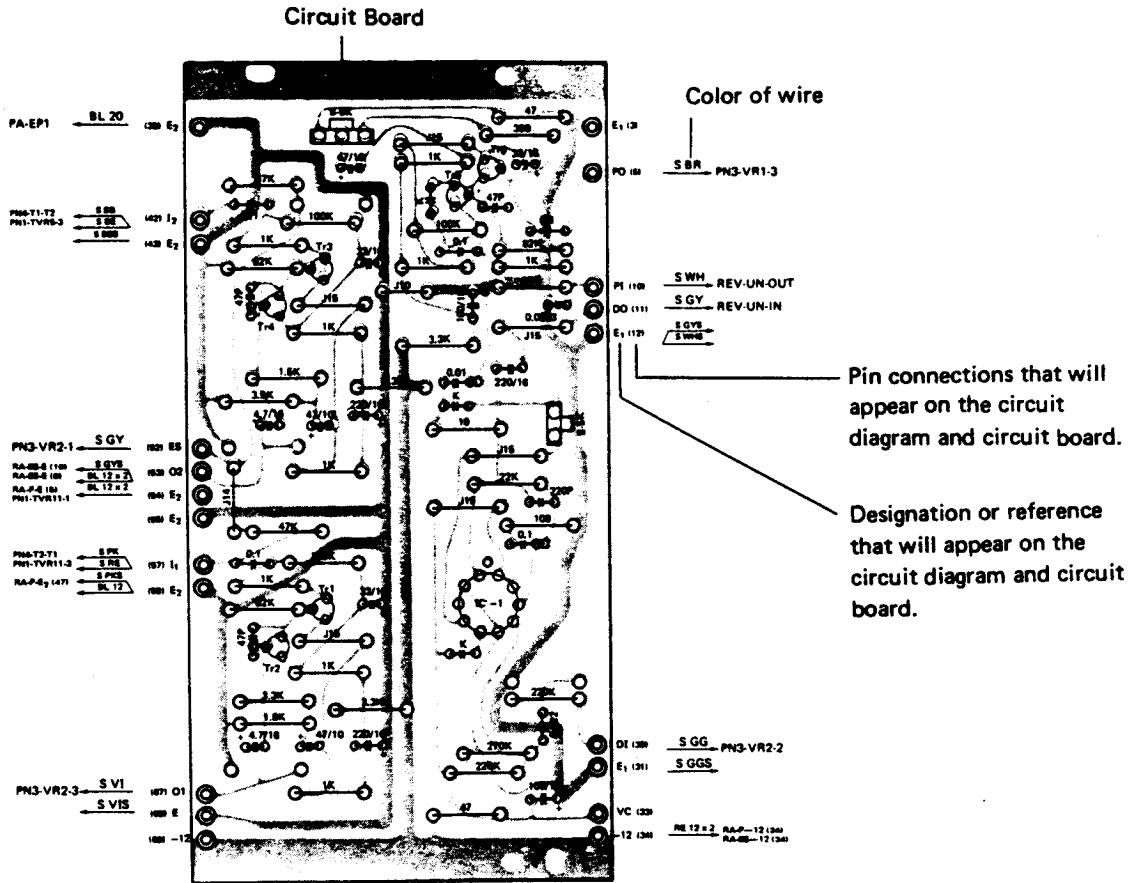

This coding states that a green wire is connected to pin 20, which is point E of the M circuit board. The other end of the wire is connected to pin 54, which is point E5 of the D circuit board, physically located on the Rack.

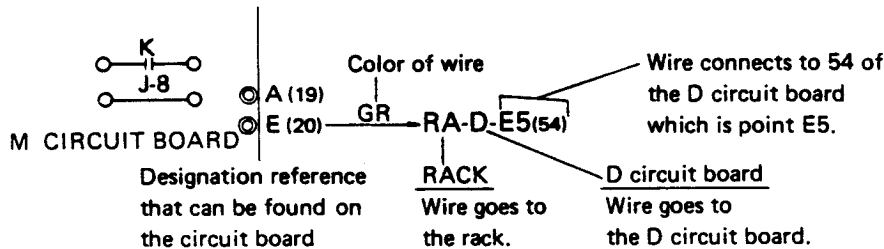

NOTE: ABBREVIATIONS OF WIRE COLOR IN ELECTONE

BL	BLACK	BR	BROWN	RE	RED	OR	ORANGE
YE	YELLOW	GR	GREEN	BE	BLUE	VI	VIOLET
GY	GRAY	WH	WHITE	GG	GRASS GREEN	SB	SKY BLUE
PK	PINK	TR	TRANSPARENT	TP	TIN PLATED WIRE		

Technical Information

1. Basic Synthesizer Theory

A "synthesizer" is an electronic instrument which utilizes changes in voltage to effect changes in tone color (waveforms), intervals (frequency) and volume (amplitude), permitting the player to freely create desired sounds.

First of all we must set forth certain basic terms which clarify how synthesizer principles compare to the basics of previous electronic musical instruments:

Previous electronic musical instruments created tone color in the following two ways, for the most part.

- 1) Composite Voicing (harmonic synthesis)
- 2) Format (filter) Voicing

The system is outlined in the following block diagram :

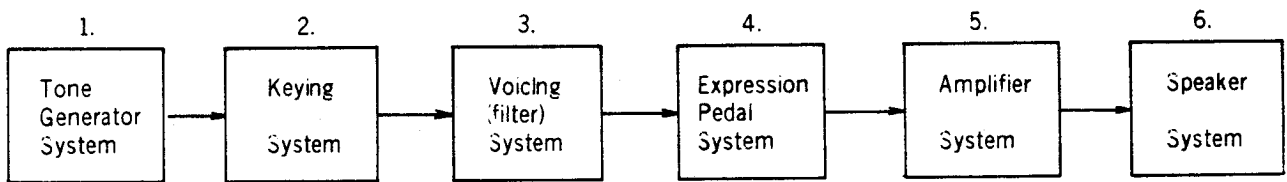

- (1) The tone generator system produces all the signals (notes) used in the organ.
- (2) The keying system controls the signals through electronic gates operated by the keys on the keyboards.
- (3) The voicing system shapes the signals to represent various instruments or voices. The organist selects which voice he wants the signals to represent by operating tabs or tone levers on the control panel.
- (4) (5), (6) These operate in the same way in the synthesizer system.

The diagram below illustrates the basic construction of the synthesizer system :

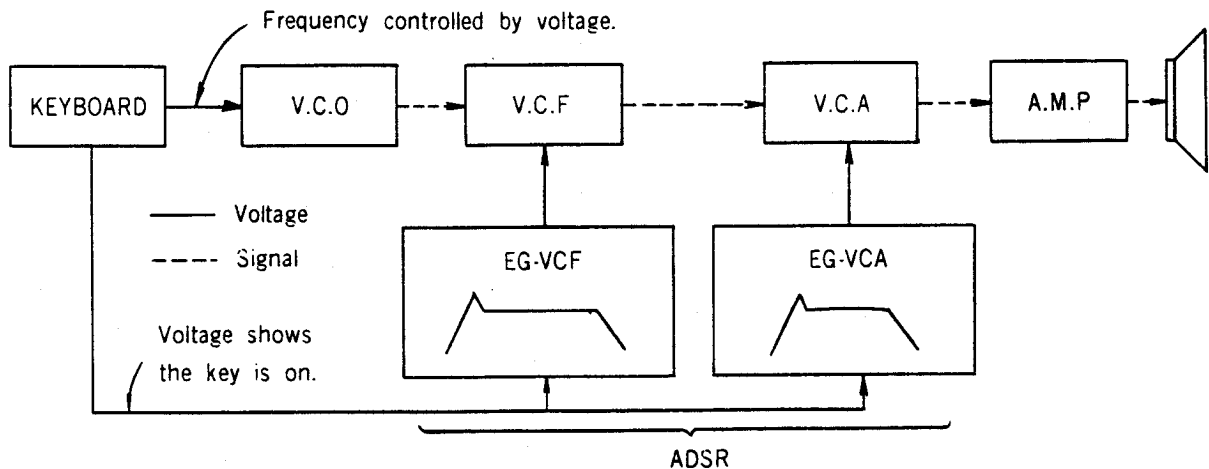

(1) VCO (Voltage-Controlled Oscillator)

The VCO is an oscillator which creates waveforms by using voltage to control oscillation frequency. In most cases the waveform is a complicated one, incorporating many short, sawtooth and pulse wave formations.

In addition to the voltage from the keyboard, other voltages can also be fed to the VCO, from other oscillators.

In the case of ultra-low frequency sine waves, a vibrato effect is created. On the other hand, the addition of square waveforms, depending upon the voltage, creates "poo-pi-poo-pi" and other types of sounds.

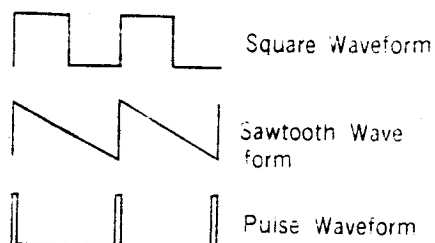

(2) VCF (Voltage-Controlled Filter)

This is a tone color circuit which adjusts the filter performance according to voltage.

The VCF changes the tone color (waveform) of voice signals sent from the VCO by adjusting the cut-off frequency and resonance according to changes in voltage.

Previous electronic organ tone color circuits worked by first using input signals in chords, with no other way to adjust except by using filters. In the synthesizer, voltage controls the operation of filters which can work with individual tones; in this way a filter circuit which can decide the output wave with fixed harmonics regardless of key is created.

(3) VCA (Voltage-Controlled Amplifier)

This circuit used voltage to control the degree of amplification.

The voltage works here to adjust changes in the rise and attenuation of signals coming from the VCF, as well as affecting attack and sustain effects.

(4) ADSR (Attack, Delay, Sustain, Release)

The conventional ADSR circuit changes the envelope in the following way, feeding the envelope to the VCF and VCO to change tone color and volume. In the Yamaha system, however, this part is already reduced, making use of EG-VFC and EG-VCA circuits.

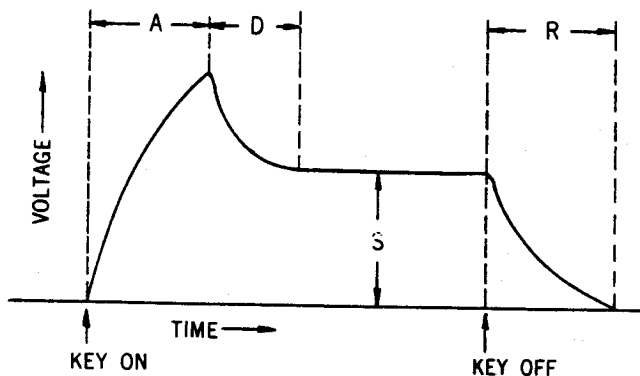

A : ATTACK TIME
D : DELAY TIME
S : SUSTAIN
R : RELEASE

(5) EG-VCF (Envelope Generator VCF)

In the Yamaha synthesizer the ADSR is designed on the basis of the EG-VCF envelope, as the figure below illustrates.

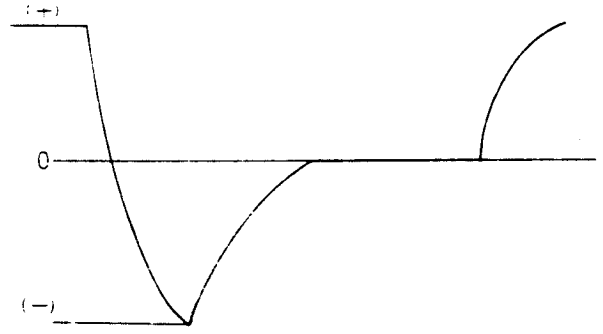
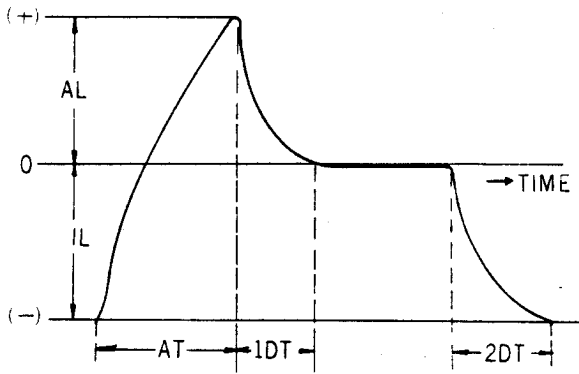

This envelope exists to create tone color changes while assuring tone color stability throughout the interval that a key is held down (except for rising and falling). For this purpose, the key On condition is taken as 0 standard basis and the envelope revolves around this standard as its center.

The EG-VCF can change or adjust the following items within the envelope waveform :

AL : Attack Level

IL : Initial Level

1DT : First Decay Time

2DT : Second Decay Time

Consequently, the VCF can also provide changes in tone color during voice signal rise and fall, according to changes in the EG-VCF envelope.

(6) EG-VCA (Envelope Generator VCF)

The EG-VCA can affect the following changes, as shown in the illustration below :

AT : Attack Time

1DT : First Decay Time

2DT : Second Decay Time

SL : Sustain Level

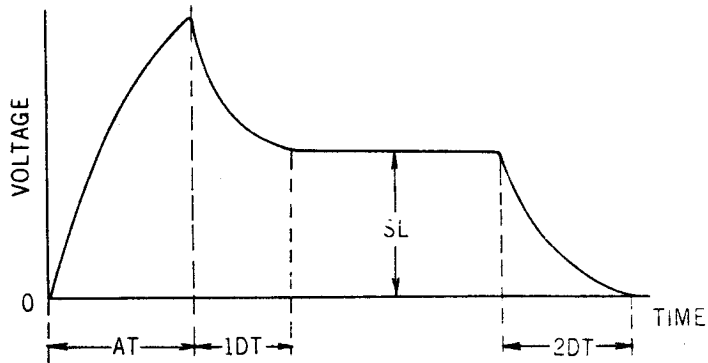

2. Yamaha Solo Synthesizer : Basic Theory

(1) Key Voltage Adjustment Circuit

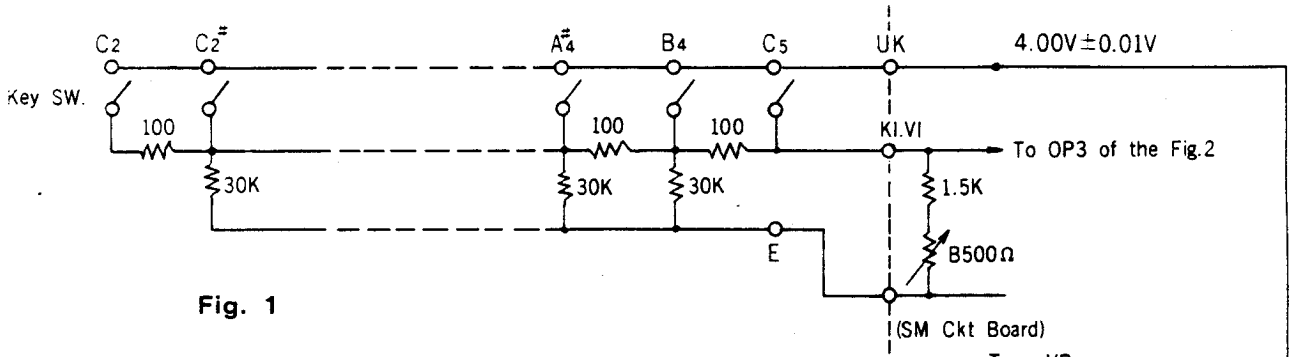
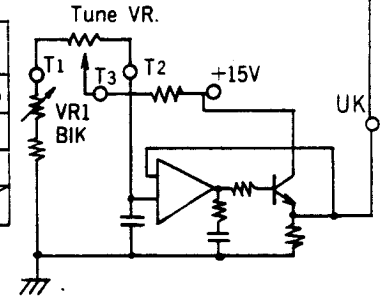

Fig. 1

NAME Key No.	C	C [#]	D	D [#]	E	F	F [#]	G	G [#]	A	A [#]	B
2	0.50	0.532	0.563	0.597	0.632	0.669	0.709	0.751	0.795	0.842	0.892	0.945
3	1.00	1.064	1.127	1.193	1.264	1.339	1.418	1.502	1.591	1.685	1.784	1.889
4	2.00	2.127	2.253	2.386	2.528	2.677	2.836	3.003	3.181	3.369	3.568	3.779
5	4.00	/	/	/	/	/	/	/	/	/	/	/

Table 1 (Terminal : KI Digital Voltmeter Input Impedance : over 100K Ω)



The Yamaha solo synthesizer creates proportional frequencies through the varied voltages applied to a single voltage-controlled oscillator by each key.

The VCO, which is controlled by the input voltage, it is an oscillator which controls the relation between input voltage and output frequency.

The voltage at terminal KI in Fig. 1 is 4.00V at C5, 2.00V at C4, 1.00V at C3 and 0.50V at C2, so this ratio is clear. From OP1 in Fig.1 a standard +4.00V \pm 0.01V is supplied. At the same time, however, the input of OP1 is a tuning voltage input, and can be used for \pm 100 Cents changes. First adjust the UK terminal for +4.00V \pm 0.01V (use VR1B1K). Next, check at VRB500 Ω on the SM circuit board that C4 is +2.00V \pm 0.01V and that all other intervals are correct according to Table 1. At this time ability absolute accuracy and Input impedance of the D.C. volt meter should be less than 0.5%, with an input impedance of over 100K Ω . An error of 0.055% in the voltage will cause a pitch variation of 1 Cent. For example, 0.055% of 4.00V is 2.2mV.

When adjusting each key, connect the fixed resistor 1.8K Ω (allowable error: \pm 0.5%) between KI and E on each ckt board, then adjust for 4.00V—2.127V (C5—C#4) consulting Table 1. In actual organs, at lower intervals this voltage may well be on the low side.

(2) Key Voltage Buffer Amp and Keying Circuit

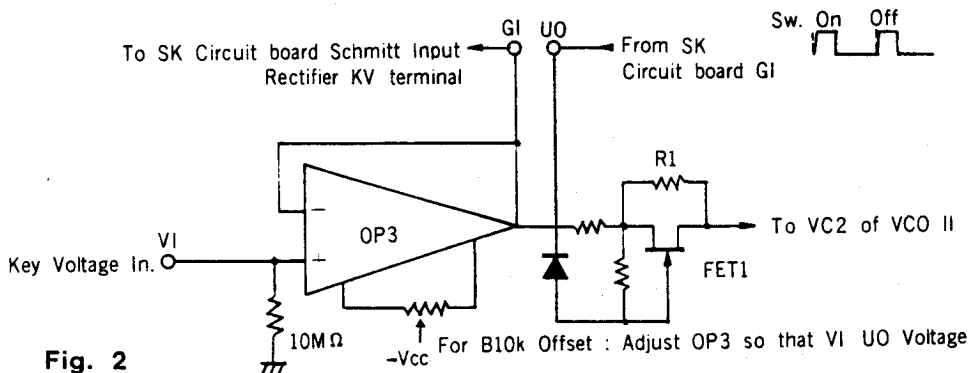

Fig. 2

Impedance is changed by OP3 to protect against drop in each key voltage, providing stable pitch voltage to VCO II.

The OP1 (operational amplifier) serves to feed the voltage of each key into non-inverting input.

DC voltage created by OP3 is fed to the SK circuit board Schmitt circuit and to FET 1 in Fig. 2. The SK circuit board creates the delay pulse required when the keyboard is switched on or off.

The above pulse is fed from SK circuit board GI terminal to FET 1 with a slight delay when the switch is turned on, in order to avoid key switch chattering. Keyboard voltage travels through FET 1 or R1 (when FET 1 is off).

(3) VCO II (Voltage Controlled Oscillator II Module)

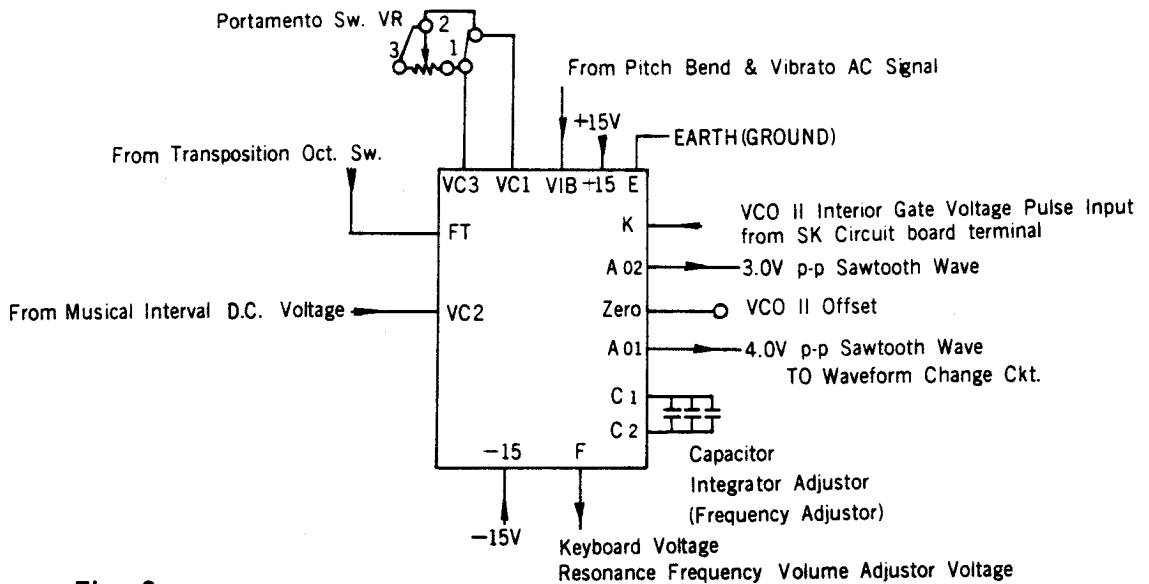

Fig. 3

Fig. 3 illustrates the VCO II module. The sawtooth wave frequency responding to input voltage is created in the VCO. Each terminal input and output is also noted. The model adjustment method requires setting to transposition normal.

Check that the voltage at the UO terminal (Fig. 2) is the same for terminal VI when C4 is pressed ; also check that this voltage is being fed to VC2.

1. Check for the determined $\pm 15V$. (DC power supply voltage)
 2. Check that a normal pulse is fed to terminal K when the key is pressed and released. There is an FET gate in VCO II ; the signal passes from SK circuit board K terminal to the VCO II K terminal.
 3. A P-P $3.0 \pm 0.3V$ ($1046Hz \pm \frac{2\%}{1\%}$) sawtooth wave is created at A02 and A0 terminals. In this case, however, an oscilloscope frequency counter is required, then the tone can be checked and adjusted in the same way as an Electone. If the VC2 input voltage is not proper under ordinary conditions, adjust with an added capacitor.
- If further adjustment of the portamento is desired it can be accomplished by inserting a VR between VC3 and VC1 of the VR11 section.

(4) Waveform Change Circuit

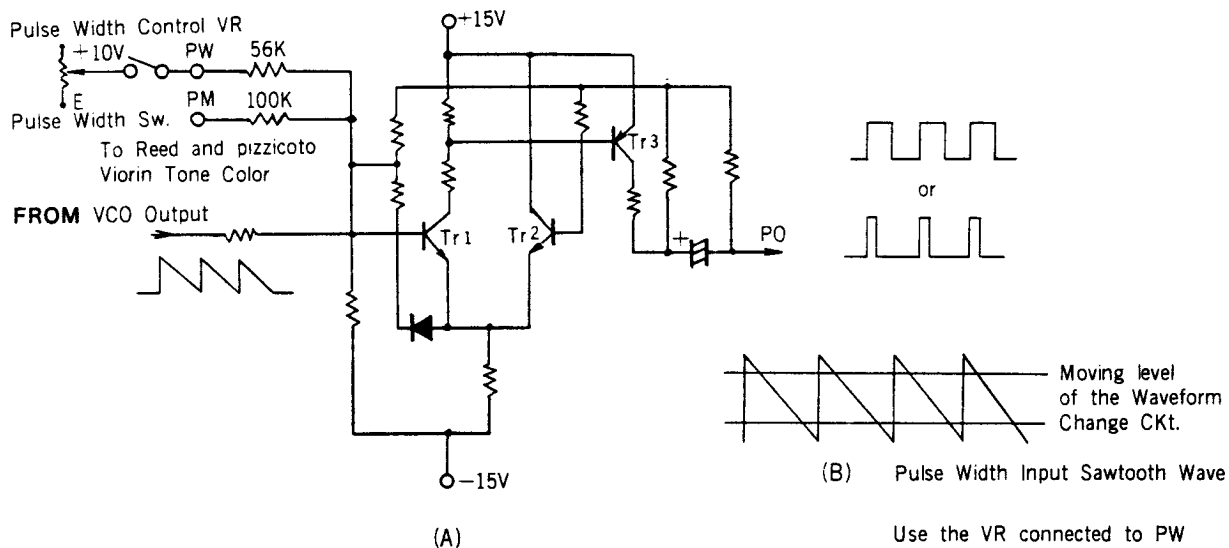

Fig. 4

Fig. 4 illustrates the waveform change circuit which permits changes in the sawtooth waveform width by short waveform transformations. It would be best if the input waveform shown in part B of the figure was changed to the width of the Tr1 action point.

However, the duty cycle ratio can be changed according to changes in the voltage of the VR connected at PW between +10V and E.

This is called "pulse width." The ratio is 50%–90%. The VCO creates a sawtooth waveform, while this waveform change circuit creates a square waveform. In order to have a waveform appropriate for the tone color, these two forms are used separately.

(5) Auxiliary Gate Circuit (For preset double and reed tones)

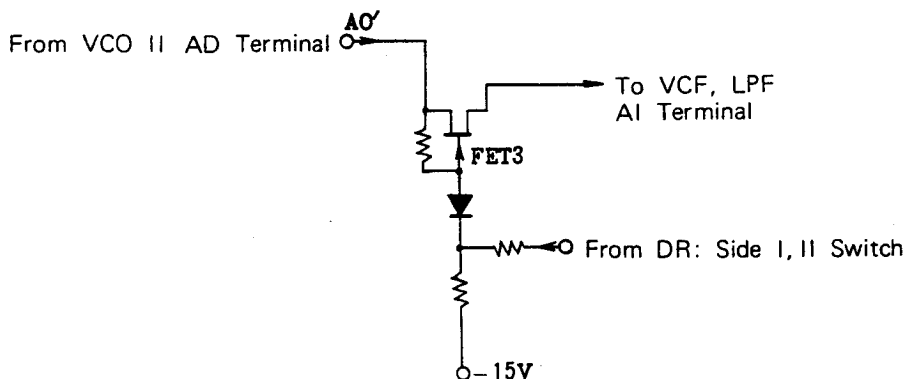

Fig. 5

When the transformed square wave and the sawtooth waveform which is VCO II output are used together, the FET 3 gate is controlled by the DR terminal, this is used for preset double and reed only.

(6) VCF : LPF, HPF (Voltage Control Filter : Low Pass, High Pass)

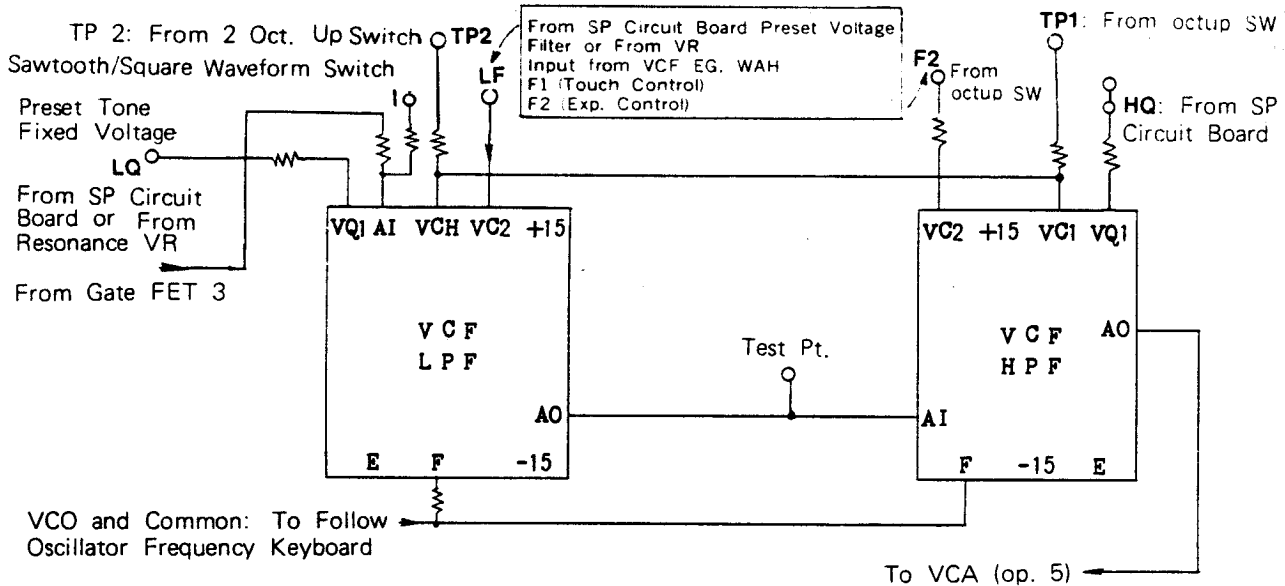

Fig. 6

Fig. 6 shows the connections between VCF : LPF and VCF : HPF. VCF is composed in the same way as VCO : of a molded circuit, so resistance to temperature fluctuations is outstanding. VCF : LPF can be thought of as a flute tone color-type waveform change filter. The various VC2 terminals of VCF feed voltage which is changeable according to touch and exp. controls, etc., providing cutoff frequency. The various fixed voltages from the preset tones and resonance VR are fed to VQ1. The resonance controls the out-off wave oscillation point by Z(ZETA): cutoff frequency resonance point of the lowpass filter. The VCF : HPF, like the VCF : LPF, is a voltage-controlled circuit which affects changes in filter characteristics. VC2 feeds in VCF EG, WAH (touch control) and Exp. control voltages. VC1, which also changes input frequency during octave up stages, feeds in varied voltage to change filter characteristics. VQ1 exists to vary filter cutoff points. AO output is fed into VCA.

(7) VCA (Voltage Control Amplifier)

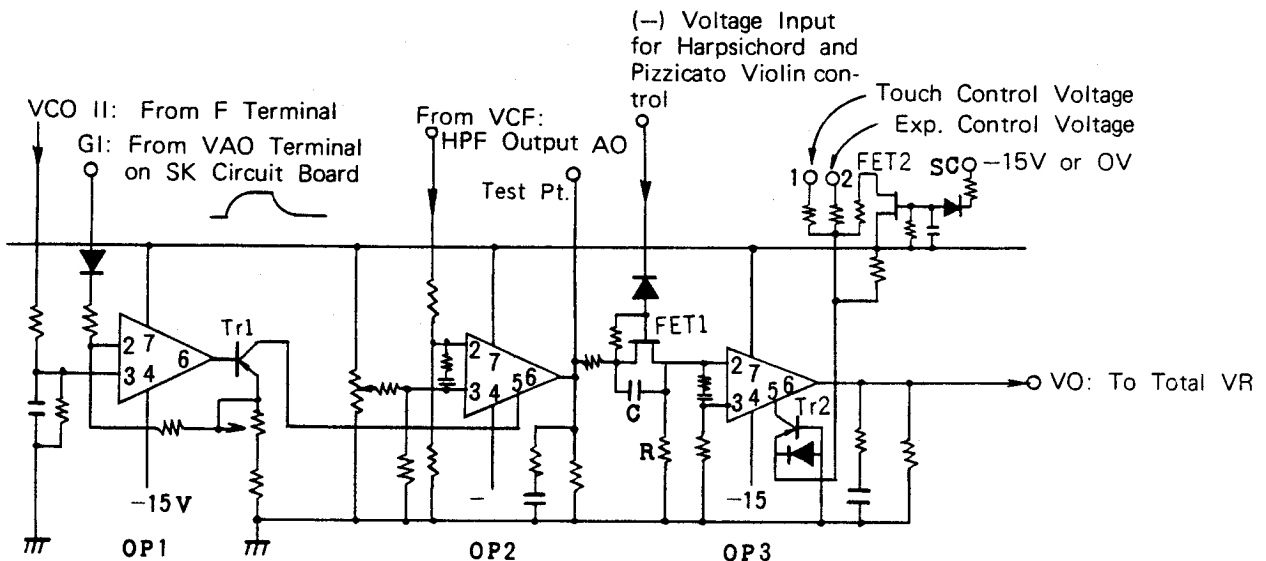

Fig. 7

The VCA circuit is illustrated in Fig. 7-1. VCF output is fed to OP2 as shown in Fig. 7. OP2 is a current control operation amplifier: its gain changes according to the current fed to terminal 5. The OP 1 input signal controls OP 2 via envelope voltage input from the SK circuit board VAO terminal. The OP 2 output which has been thus controlled either passes through the FET1 or (for harpsichord and pizzicato violin only) creates (-) voltage at the FET1 gate, thus passing through capacitor C only and working with the CR bypass filter to cut bass click noise. OP 3 is also a current control type OP amplifier. According to touch control and exp. control voltage inputs from 1 and 2 Tr2 emitter potential rises, causing current to flow between (5) and (E) in OP 3. The SC terminal can control via terminals 1 and 2 when they are used by feeding -15V to the FET2 gate and thus shutting the FET2 off. However, if terminals 1 and 2 are not used, the FET2 is normally on, thus supplying a fixed current to terminal 5 of OP 3 via the resistor. Thus a buffer amp input is provided via total VR. Output waveform is shown in Fig. 7-1.

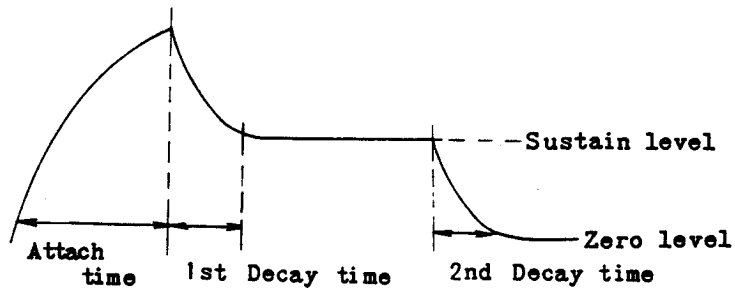

Fig. 7-1

(8) Output Amplifier and Click Noise Avoided Circuit

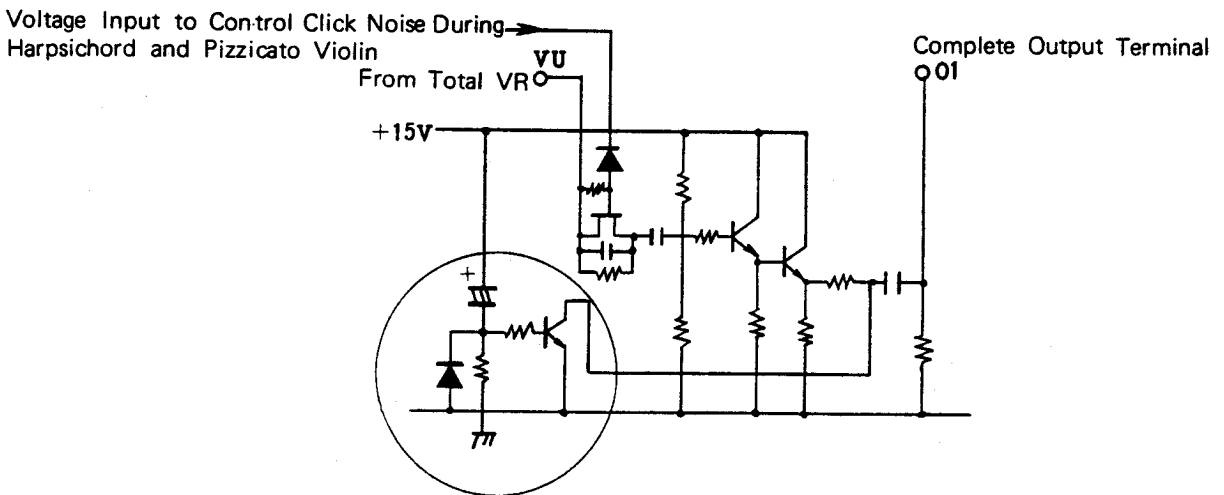

Fig. 8

Fig. 8 shows the output amplifier circuitry. When harpsichord or pizzicato violin signals mixed with the input signal, in order to control click noise (-) voltage is supplied, shutting off the FET. The signal passes through the capacitor and resistor, effectively cutting out click noise. Terminal 01 output impedance is approximately 600Ω, so 0dB output voltage is provided.

The circled circuit in Fig. 8 serves to avoid click noise when the power is switched on. At this time the transistor switches on to short all output signals; then the capacitor charges and the transistor switches off for normal output signal.

(9) VCF EG (VCF Envelope Generator), VCA EG

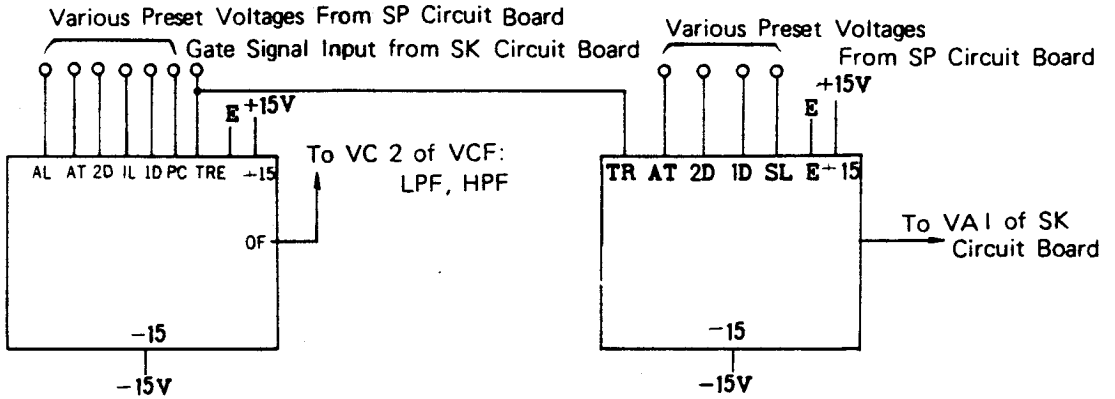

Fig. 9

Fig. 9 shows the VCF EG and VCA EG module circuits. When +10V is fed to the PC terminal, VCF EG takes 0 level as its center and rises to the + side, then lowers to create the output waveform at OF like that shown in Fig. 10-1. When -10V is fed to the PC terminal, a waveform converse to that shown in Fig. 10-1 appears as output at OF. Terminals AL, AT, 2D, IL, ID and PC create voltage waveforms which match the tone color of the preset voltage inputs from the SP circuit board. These waveforms are fed to VC 2 of VCF, LPF and HPF as inputs, changing the filter sawtooth wave frequencies to create the various preset tone waveforms.

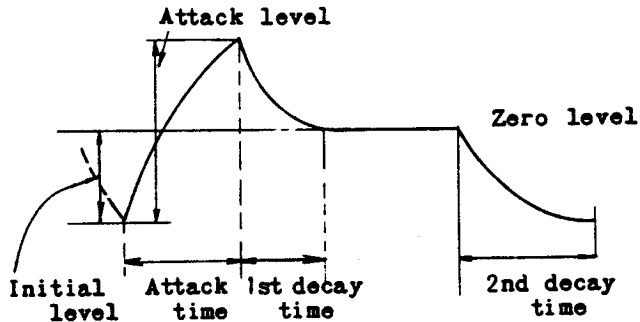

Fig. 10-1

(10) Oscillator Types

9-1. Vibrato Oscillator

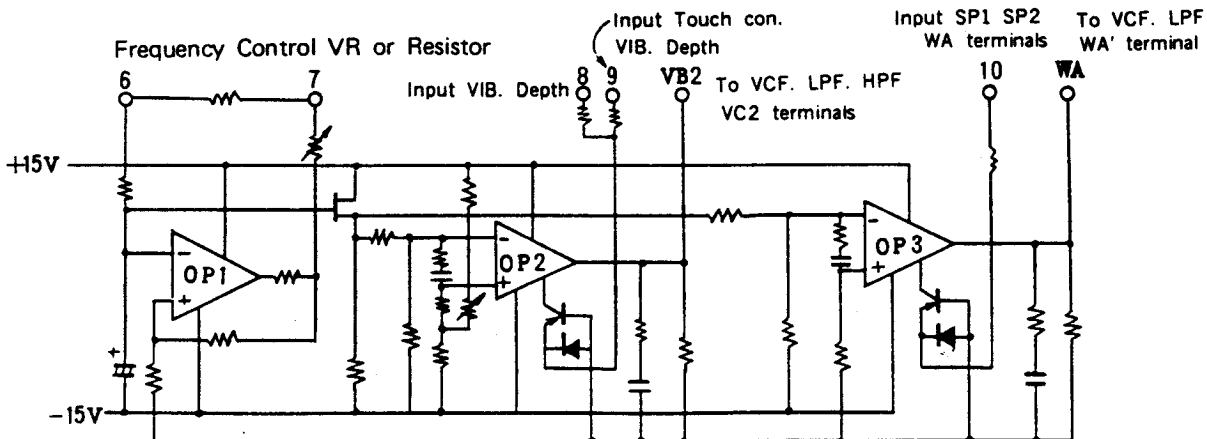
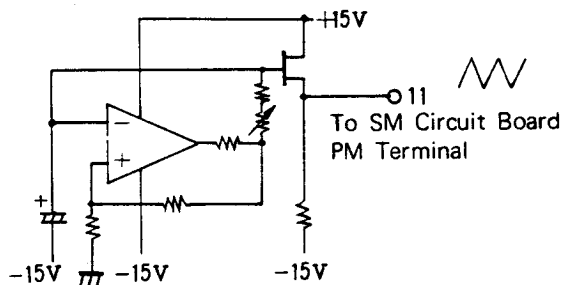

Fig. 11 illustrates the circuitry of the vibrato oscillator.

When the (-) terminal potential is less than the (+) terminal, current flows from C through the VR and resistor between 6 and 7. When the potential is higher in the (-) terminal, OP 1 output is reversed. (-) terminal potential becomes that of the (-) terminal and C discharges through the resistance between 7 and 6. When the (-) terminal potential drops lower than that of the (+) terminal, the original condition recurs. This back and forth motion in the (-) terminal creates a constant charge-discharge pattern in the capacitor, giving rise to a triangular waveform. Between 6 and 7 is a vibrato speed VR connected to SP of the SP circuit board. When the VR resistance is high, OP 1 frequency is low. By the action of the vibrato depth control voltage input at terminal 8 and the touch control vibrato depth voltage input at terminal 9, OP 2 gain is controlled. This signal is fed from the VB2 terminal to the various VC2 terminals of the VCF, LPF and HPF. Terminal 10 feeds the controlled signal from the WA terminals of the SP1 and SP2 circuit boards to VC2 on the VCF, LPF and HPF, thus acting as a control. This untouched signal is wah guitar vibrato.

9-2. Double, Reed Preset Tone Oscillator



This section works on the same principle as the vibrato oscillator: output impedance is lowered thanks to the FET. The vibrato effect is created by adding the signal from terminal 11 to the preset double and reed tones.

(11) Exp. In Buffer Amp, Touch Control Detector Buffer Amp

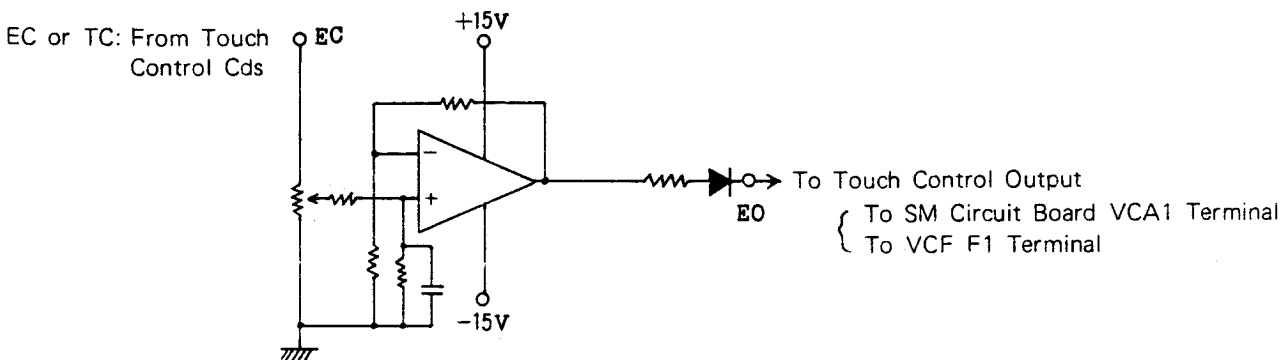
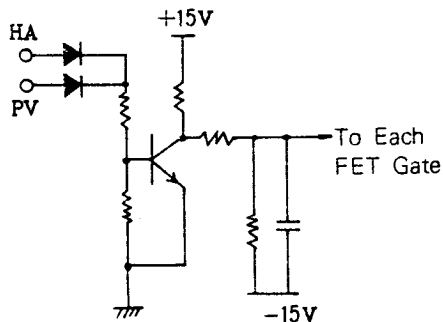

Fig. 13 illustrates the circuitry of the Exp. In control buffer amp and the touch control detector buffer amp. This amplifier serves to make the control voltage optional, and also to keep output impedance low. Input and output signals are unified, and (+) voltage appears at the output.

(12) Harpsichord and Pizzicato Violin Click Prevention Voltage Switching Unit



(+) input is fed from HA and PV in Fig. 14, switching the Transistor on and reducing output resistance to -15V. When the voltage becomes negative a slight delay can be created by the capacitor, cancelling click noise in the PST switch.

Fig. 15 shows the circuitry for the tone color basic oscillator which functions for the various gate pulse circuits, pitch bend and tone bend circuits and SP1 & SP2 circuit boards. Fig. 16 shows the pulse waveforms for the various terminals.

Keyboard voltage is fed to terminal KV. OP1 works as a transformation amp to differentiate between these outputs. It contains a rectifier circuit which changes the positive/negative pulses of the Tr1 output which passes through buffer amp OP2 into positive-only, then feeds them as input to one-shot multivibrator I and II. One-shot multivibrator 1 uses the Tr10, Tr11 delay circuit to feed delay pulses from terminal G1.

At the same time, the Schmitt trigger creates pulses like that shown in the figure by feeding the pulses created by Tr7 and Tr8, then delayed by Tr16 and Tr17, from terminal AG. The AG signal is fed to AG; and it passes to the pitch bend circuit P2. It then passes from the PB terminal as input to the VCO II VBI terminal. The waveform created by the Schmitt trigger circuit and the one-shot multivibrator of Tr5 and Tr6 passes from terminal K and is used to create the pulse shown in the figure, driving the gate circuit in the VCO II.

In order to feed the waveform created by VCA EG to VCA as input from terminal VA I, output is fed from VAO. However, when the key is first pressed turning the switch on, Tr27 is off, so the signal from VA I passes to VA O.

When another key is pressed Tr27 goes on momentarily and the signal does not pass from VA I to VA O. Previous control voltage to VCA is cancelled. Thus an integral circuit, composed of a 10KΩ resistor and 0.1μF capacitor, is formed to prevent click noise when a key is first pressed.

TB is a special output terminal for tone bend, fed by VCF LPF. The LC terminal is controlled by the attack bend intensity VR, thus controlling the TB output voltage.

OP7 is a basic voltage amplifier, supplying +10.6V to the SP1 and SP2 circuit boards. Therefore +10.6V is fed from the +10 terminal.

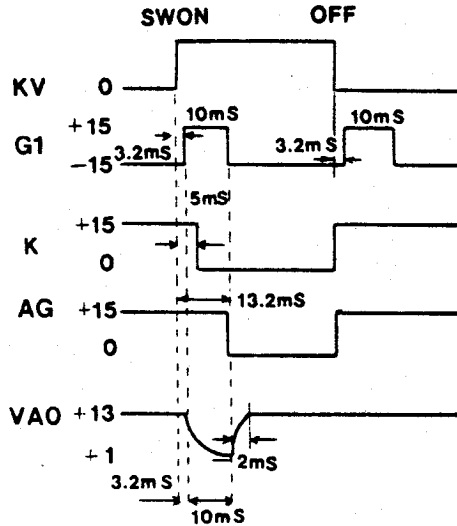

Fig. 6 Output Waveform at Each Terminal

3. Concerning Modules

In order to create temporal changes in pitch, waveform and volume these modules work by control from very small amounts of voltage.

Modules are made up of C. R. Tr and IC, etc. component parts, and in order to assure high reliability a composite resin filler is used. In distinguishing good and faulty modules there is a basic method to be used, described on the following pages.

(1) VCO II (NE-10200) Voltage Controlled Oscillator

The oscillator frequency (f), which is the tone source, is compared to control voltage (E).

$$f = KE \quad (K : \text{fixed value})$$

1. Sample Hold FET Test

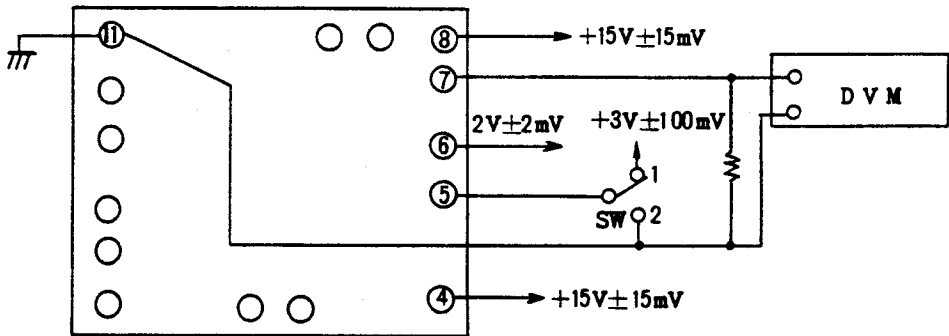

During switch 2 the digital voltmeter should indicate $2V \pm 30mV$.

During switch 1 the digital voltmeter should indicate $0V \pm 2mV$.

2. Oscillator Frequency Adjustment

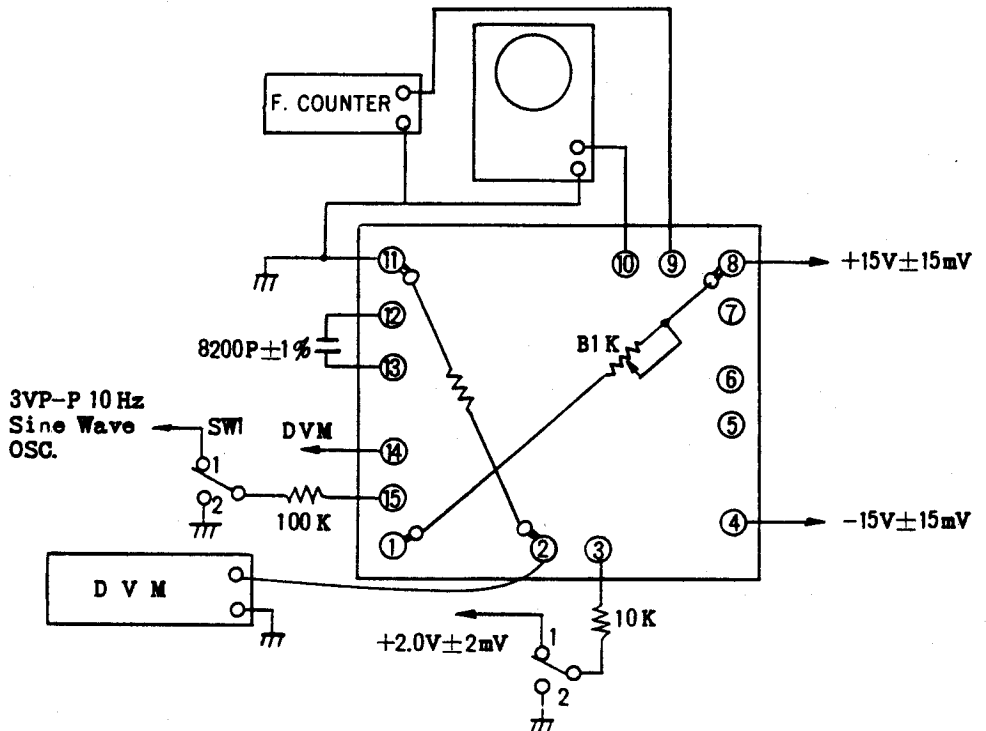

2-1. Zero Adjustment

Connect as shown in the figure, and set both switch 1 and 2 to condition 2. Adjust the exterior VR B1K so that the DVM indicates $\pm 1\text{mV}$. Then disconnect the DVM and set switch 2 to condition 1. Then, when the DVM is connected to terminal 14 the reading should be within the limits of $2\text{V} \pm \begin{matrix} 0.8\text{V} \\ -3\text{mV} \end{matrix}$

2-2. Oscillator Frequency

Use an oscilloscope to check that a sawtooth waveform of approximately 4V p-p is present at the output. Frequency counter reading should be $1060 \pm 200\text{Hz}$.

2-3. Output Waveform and Offset Voltage Adjustment

Adjust VR1 so that the oscilloscope shows a $4\text{V} = 100\text{mV}$ sawtooth waveform. If a sliced waveform appears at the output at this time, adjust VR2 to the proper value.

Adjust VR2 so that DC offset voltage is $\pm 100\text{mV}$.

2-4. Vibrato

When switch 1 is set to condition 1 vibrato should appear on the oscilloscope waveform.

2-5. Output Waveform for Audio.

Connect the oscilloscope to (10) and check that the waveform is $3\text{V} = 0.6\text{V p-p}$.

(2) VCF-LPF (NE-10400)

VCF: Voltage Controlled Filter

LPF: Low Pass Filter

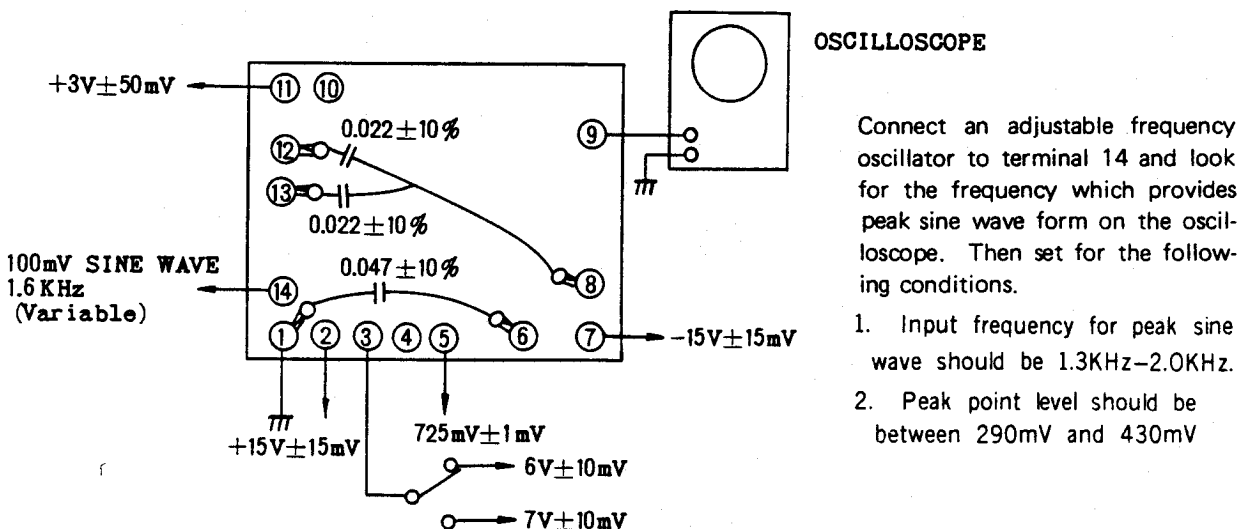
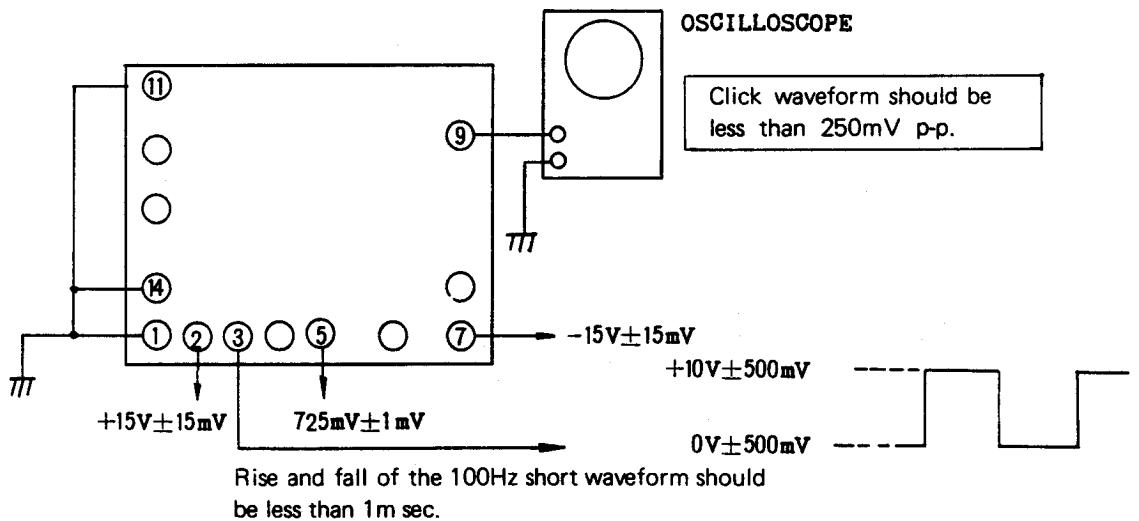

(3) VCF-HPF (NE-10500)

VCF: Voltage Controlled Filter

HPF: High Pass Filter

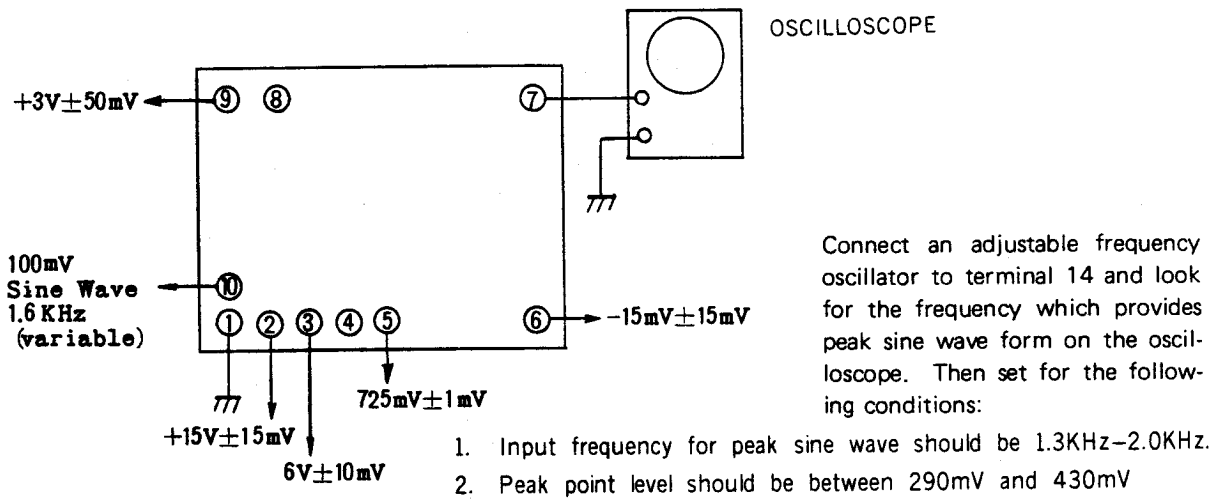
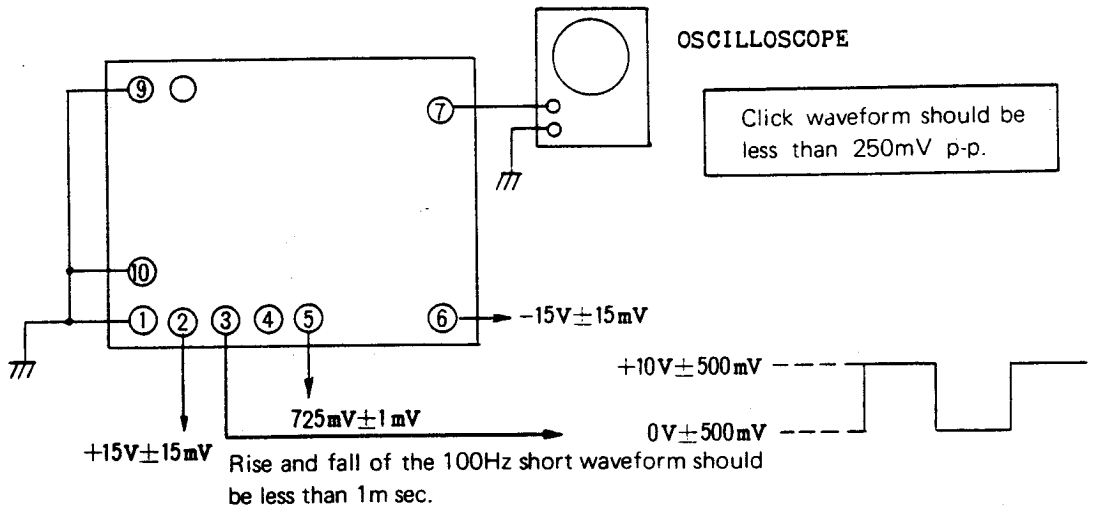

(4) EG-VCF (NE-10800)

EG: Envelope Generator

VCF: Voltage Controlled Filter

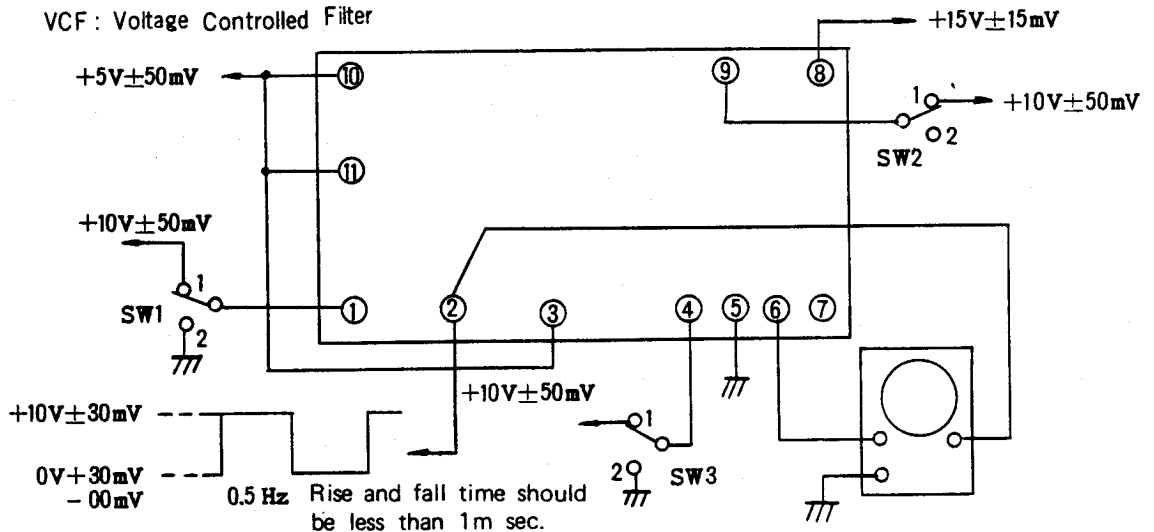

1. The following waveform would appear on the oscilloscope when switches 1, 2 and 3 are set to condition 1.

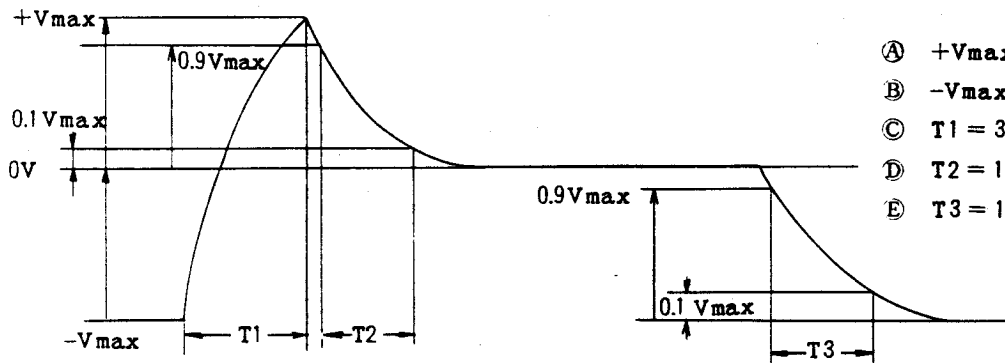

- Ⓐ $+V_{max} = +5V \pm 0.5V$
- Ⓑ $-V_{max} = -5V \pm 0.5V$
- Ⓒ $T1 = 31\text{ms} \pm 7\text{ms}$
- Ⓓ $T2 = 180\text{ms} \pm 40\text{ms}$
- Ⓔ $T3 = 180\text{ms} \pm 40\text{ms}$

2. When switch 3 only is set to condition 2 the above waveform should be reversed (with GND as center).
3. When all three switches are in condition 2 the click waveform on the oscilloscope should be less than 50mV p-p.

(5) EG-VCA (NE-10900)

EG: Envelope Generator

VCA: Voltage Control Amplifier

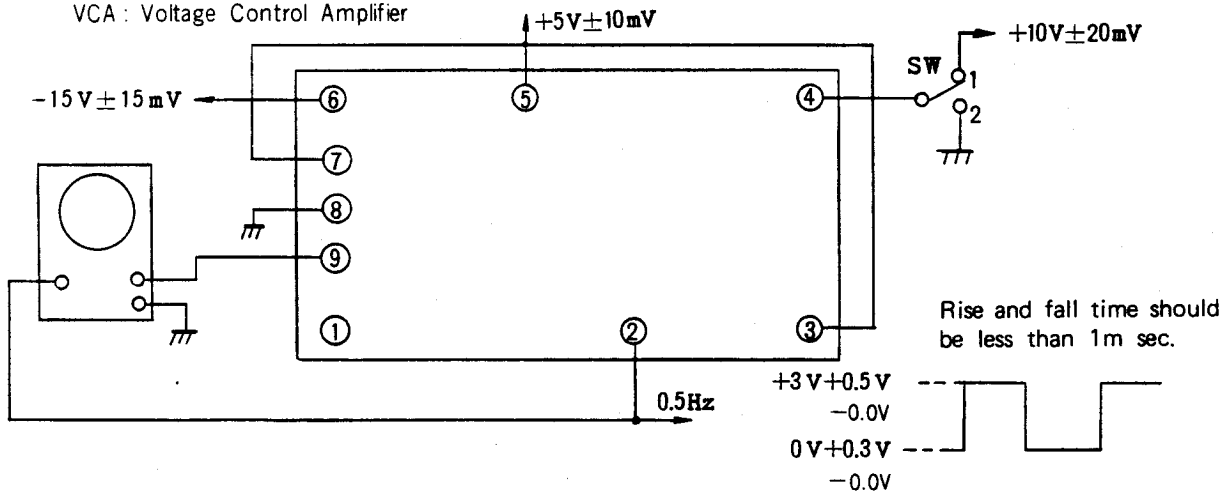

CHECK POINT	SW POSITION	WAVE	REMARKS
ATTACK TIME	2		$T1 = 31\text{ms} \pm 7\text{ms}$
FIRST DECAY TIME	2		$T2 = 180\text{ms} \pm 40\text{ms}$
SECOND DECAY TIME	1		$T3 = 180\text{ms} \pm 40\text{ms}$

(Note) $V_{max} = 10.0V \pm 0.5V$

PN1

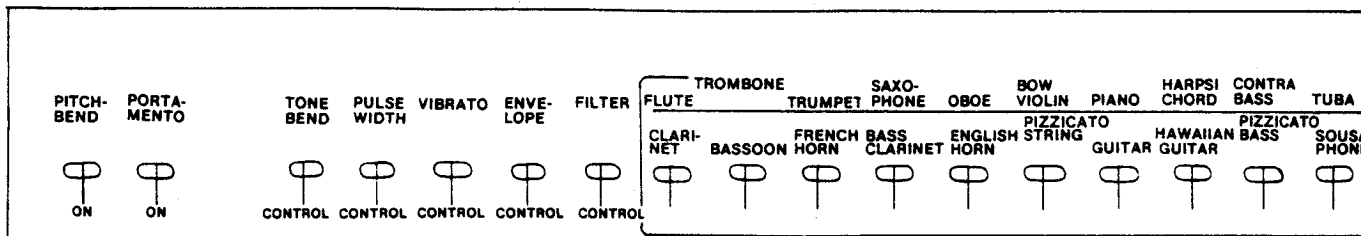

PN2

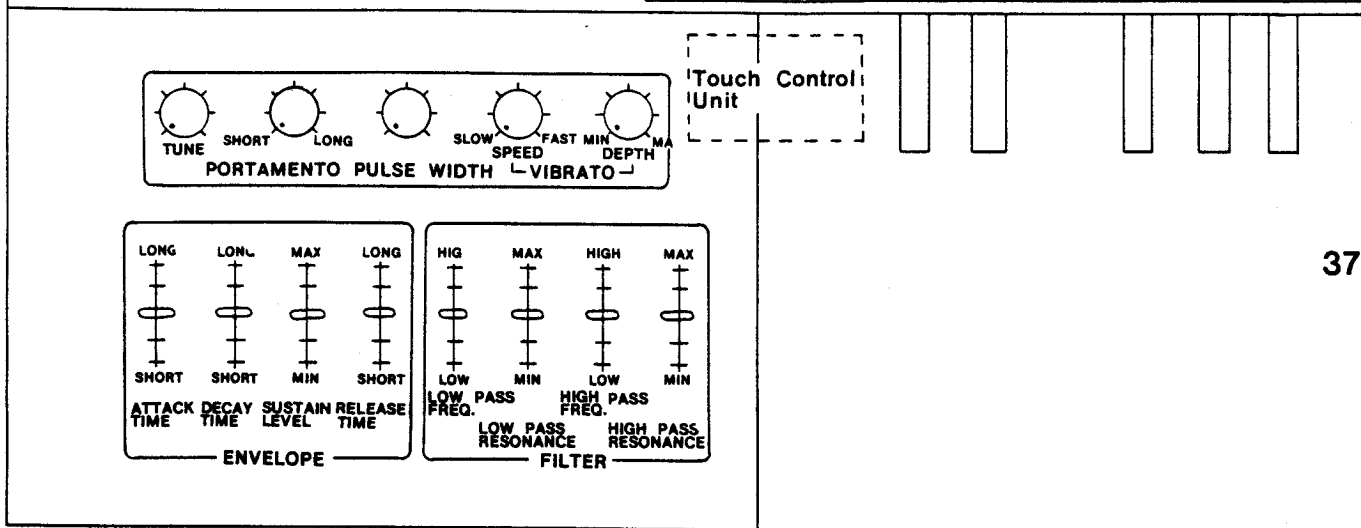

37

The voltage selector is attached only General, South African and European models.

PN4

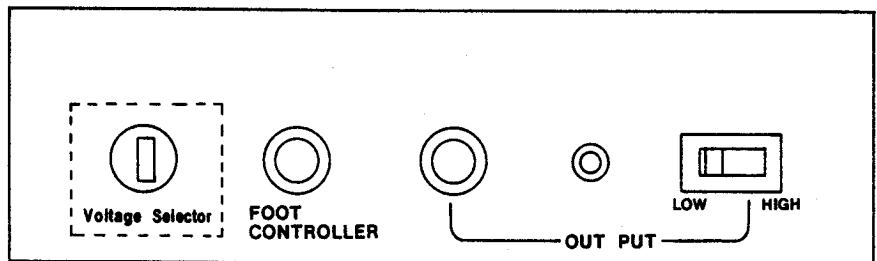

INSIDE REVIEW

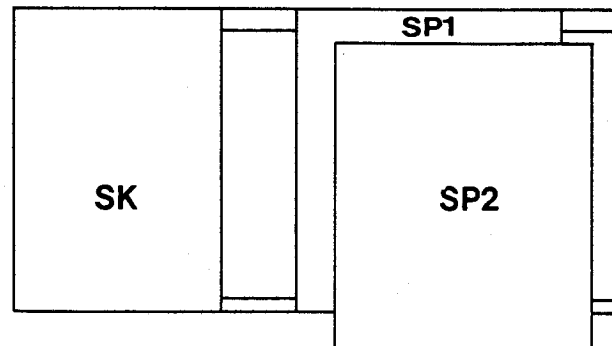
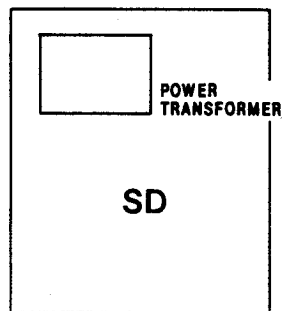

view & Back view

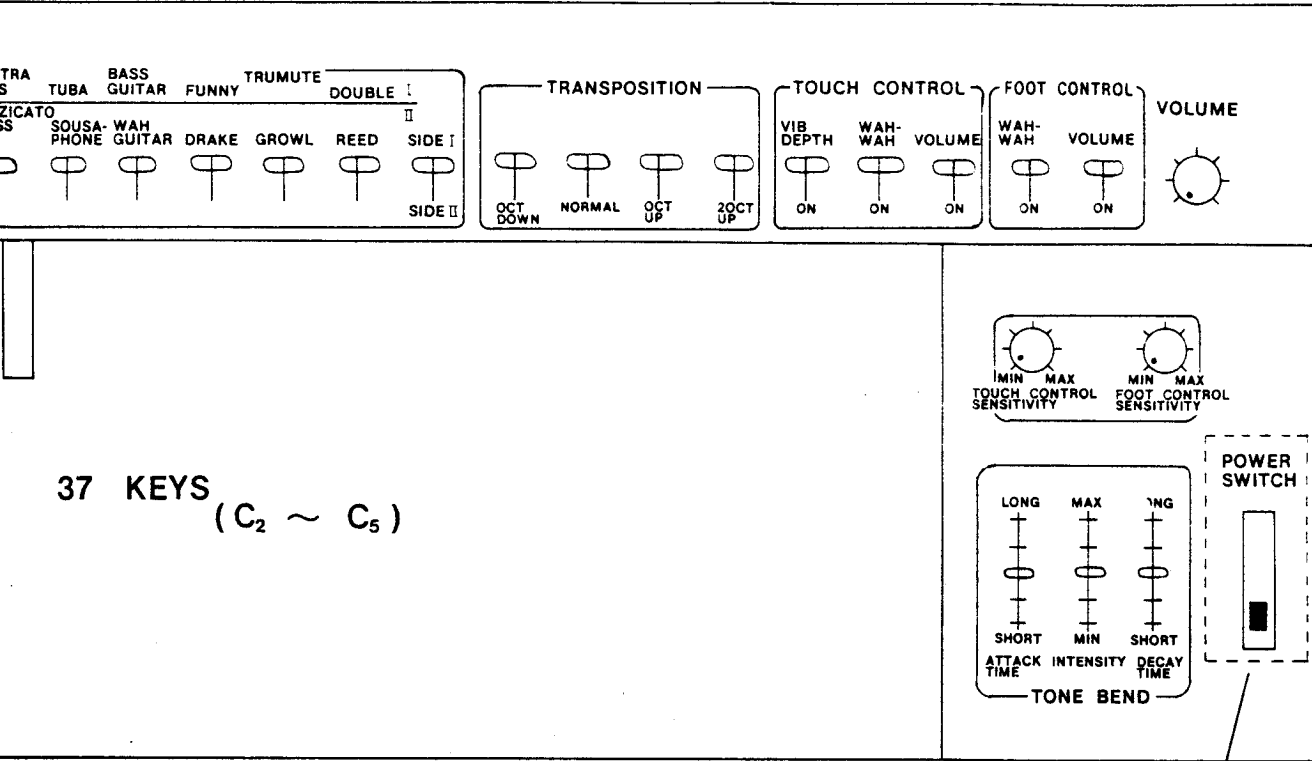

37 KEYS (C₂ ~ C₅)

PN3

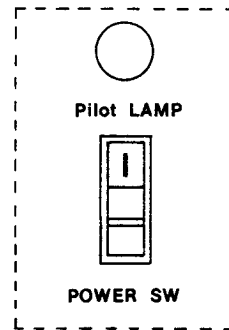

North European model only.

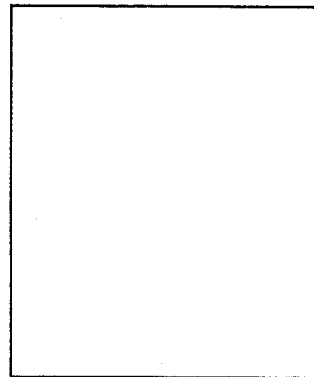
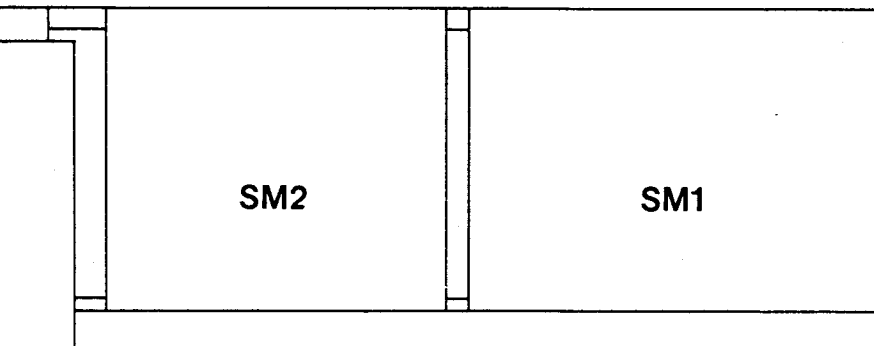

Diagram

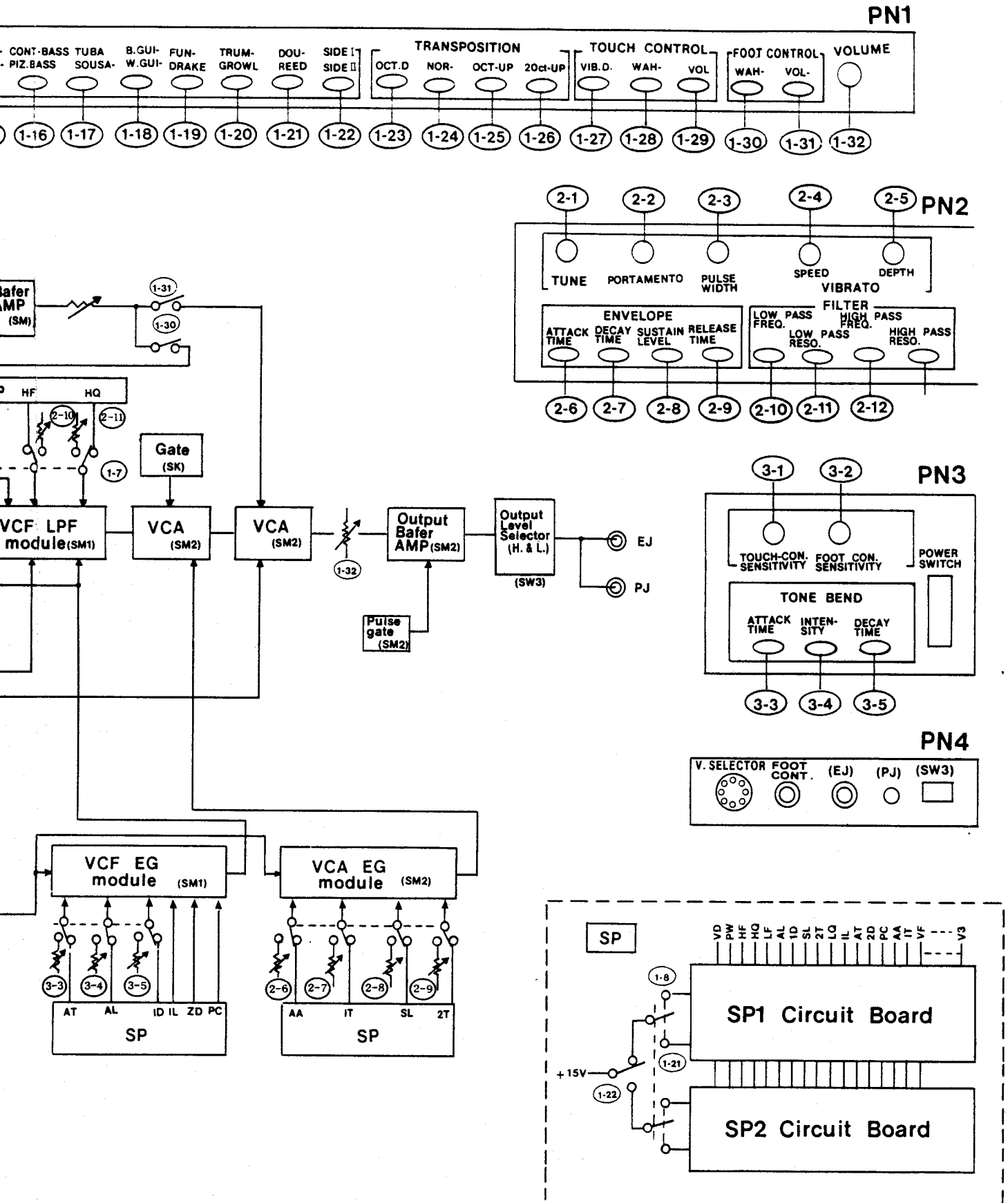

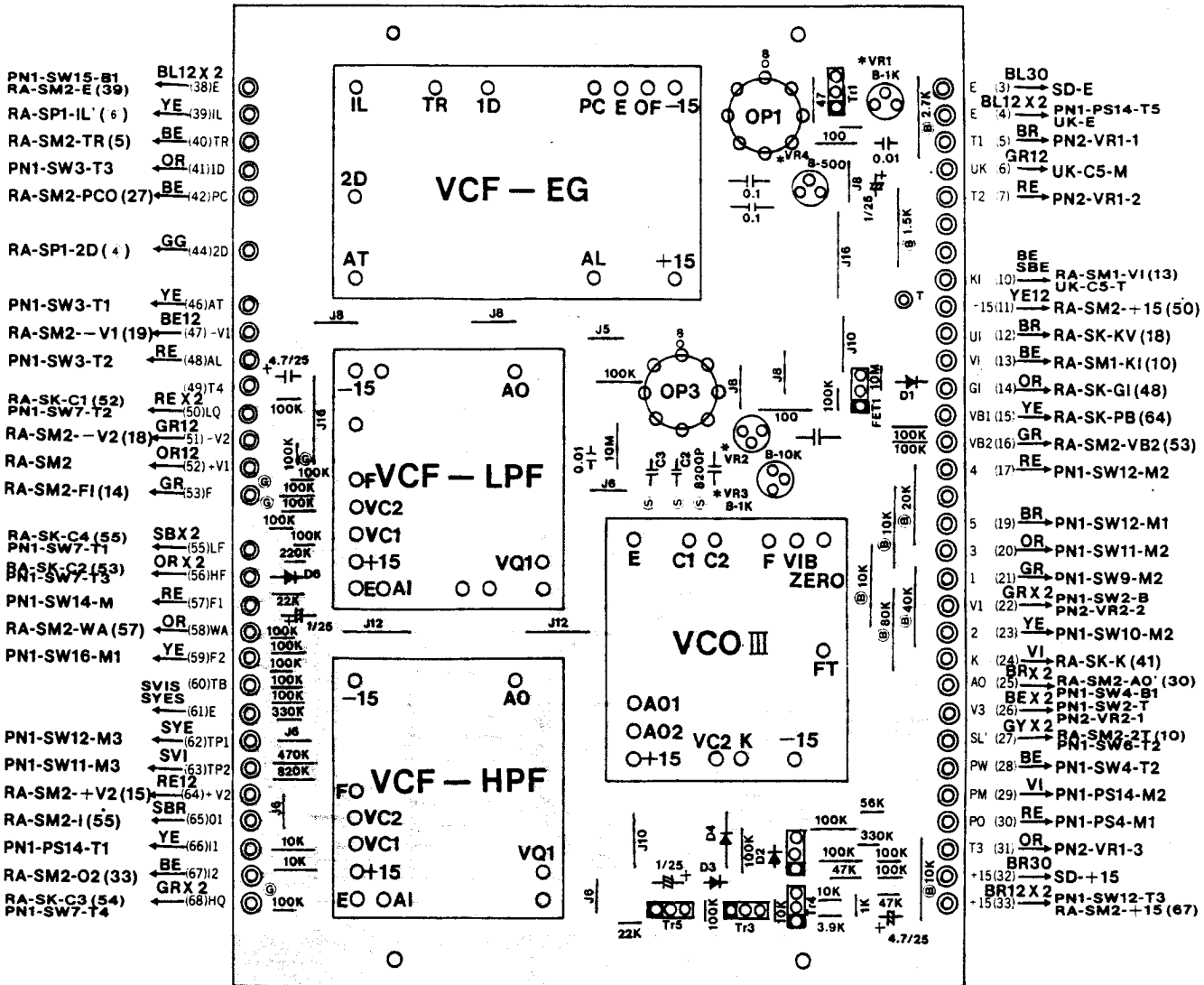

SM1 Transistor FET
Voltage Chart (at Tester)

	E	C	B
Tr 1	+ 4	+15	+ 4
2	- 0.4	+14	- 0.2
3	- 0.4	+15	0
4	+15	+ 7	+14.6
5	0	0	+ 0.7
FET 1	- 0.1	-14.6	0

How to tune.

1. Set the voltage adjustor of the D.C. power supply to $\pm 15V \pm 0.01V$.
2. Set the tuning VR. with center position at panel-2.
3. Adjust the potentiometer VR1(B-1K) to $+4.00V \pm 100 \mu V$ at the terminal UK on the SM1 circuit board.
4. Adjust the potentiometer VR4(B-500Ω) to $+2.00V \pm 100 \mu V$ with depress C4 at the terminal UI on the SM1 circuit board.
5. Connect the Earth to the terminal UI, set the offset voltage of the operational amplifier OP3 to less than $\pm 100 \mu V$ at terminal UO by the potentiometer VR2 on the SM1 circuit board.

SM2 Circuit Diagram

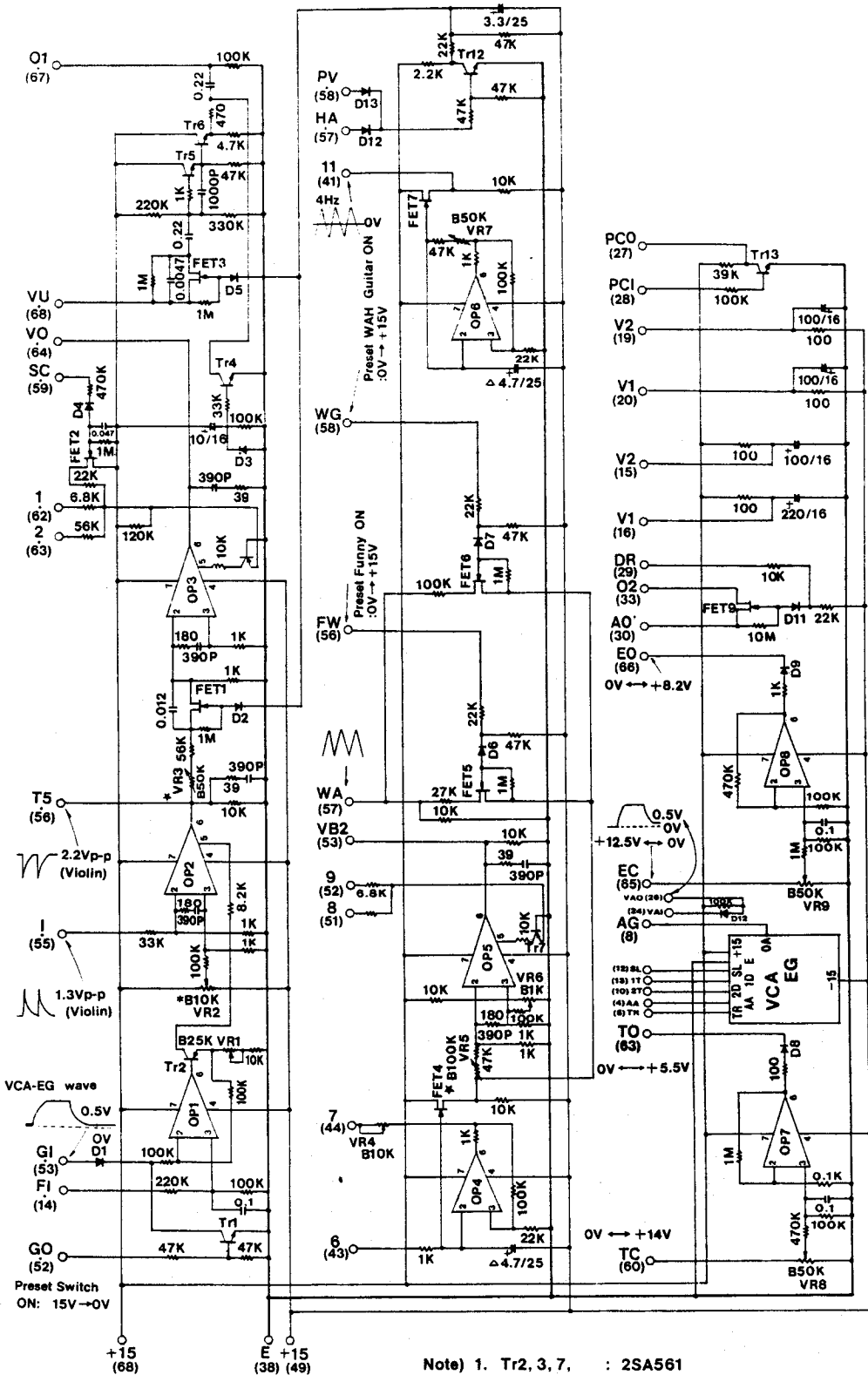

- Note 1. Tr2, 3, 7. : 2SA561
 Others : 2SC458
 FET : 2SK30
 Diode : 1S1555
 2. OP1, 4, 6, 7 : TA7504M (μ A741HC)
 OP2, 3, 5 : CA3080
 3. * Marked VR : Cermet type
 Variable resistor 3321H
 4. * Marked VR : Two terminals Variable
 Resistor
 5. Others VR : 18K3-1
 6. Δ Marked : Tantalum Capacitor

SK Circuit Diagram

Marked ▽ : Key ON
Marked ▼ : Key OFF

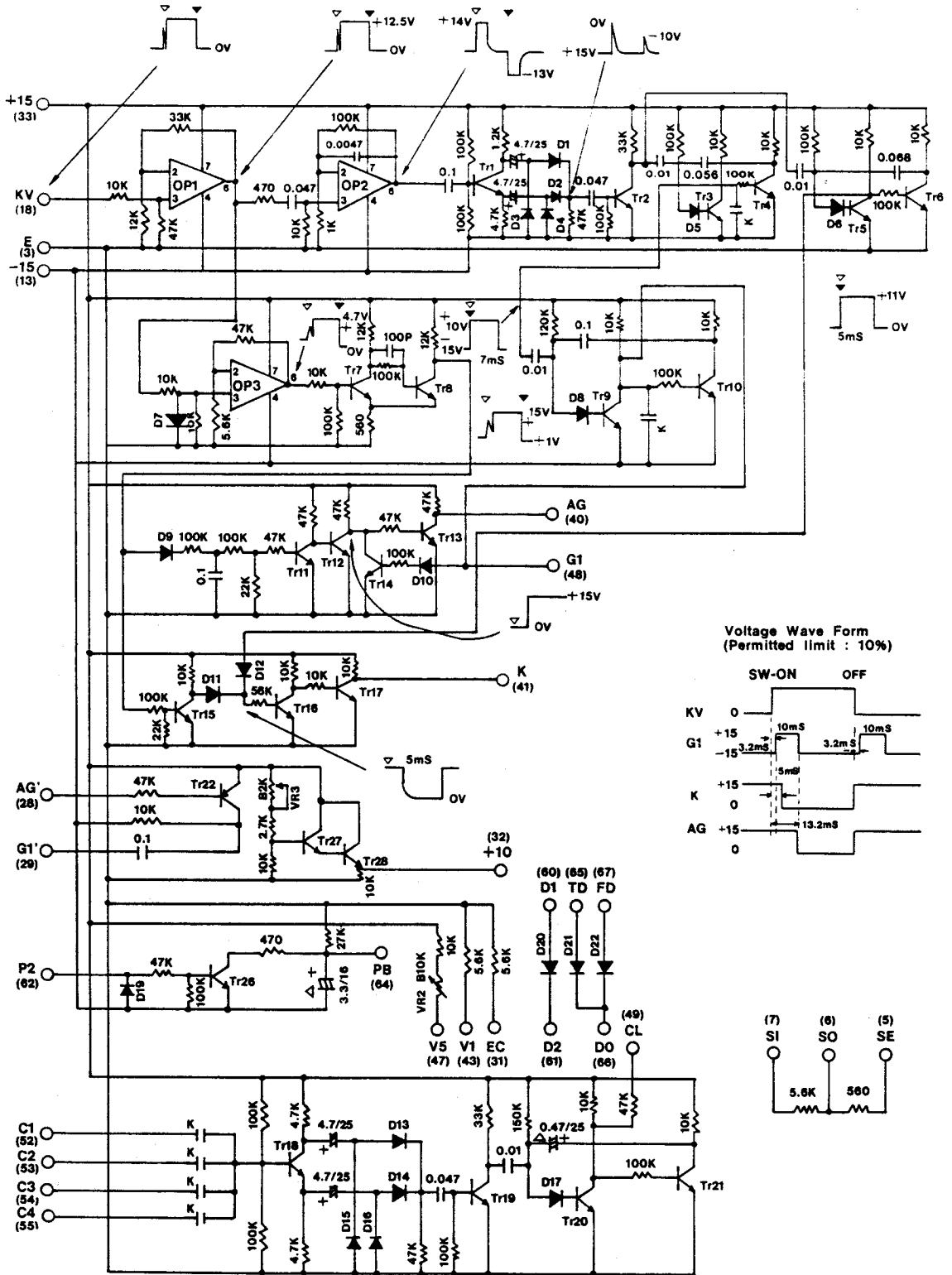

Voltage Wave Form
(Permitted limit : 10%)

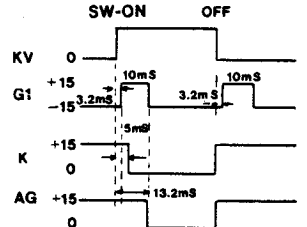

- Note) 1. Transistors
 Tr5, 6, 16, 17 : 2SC752
 Tr22 : 2SA561
 Others : 2SC828 (2SC458)
2. Diode
 D1 D22 : 1S1555
3. OP. 1, 2, 3 : TA7504M (≠ A741HC)
4. Marked K : Ceramic Capacitor 1,000pF.
5. Marked Δ : Tantalum Capacitor.
6. VR : Two Terminals Variable Resistor.

SP1 Circuit Diagram

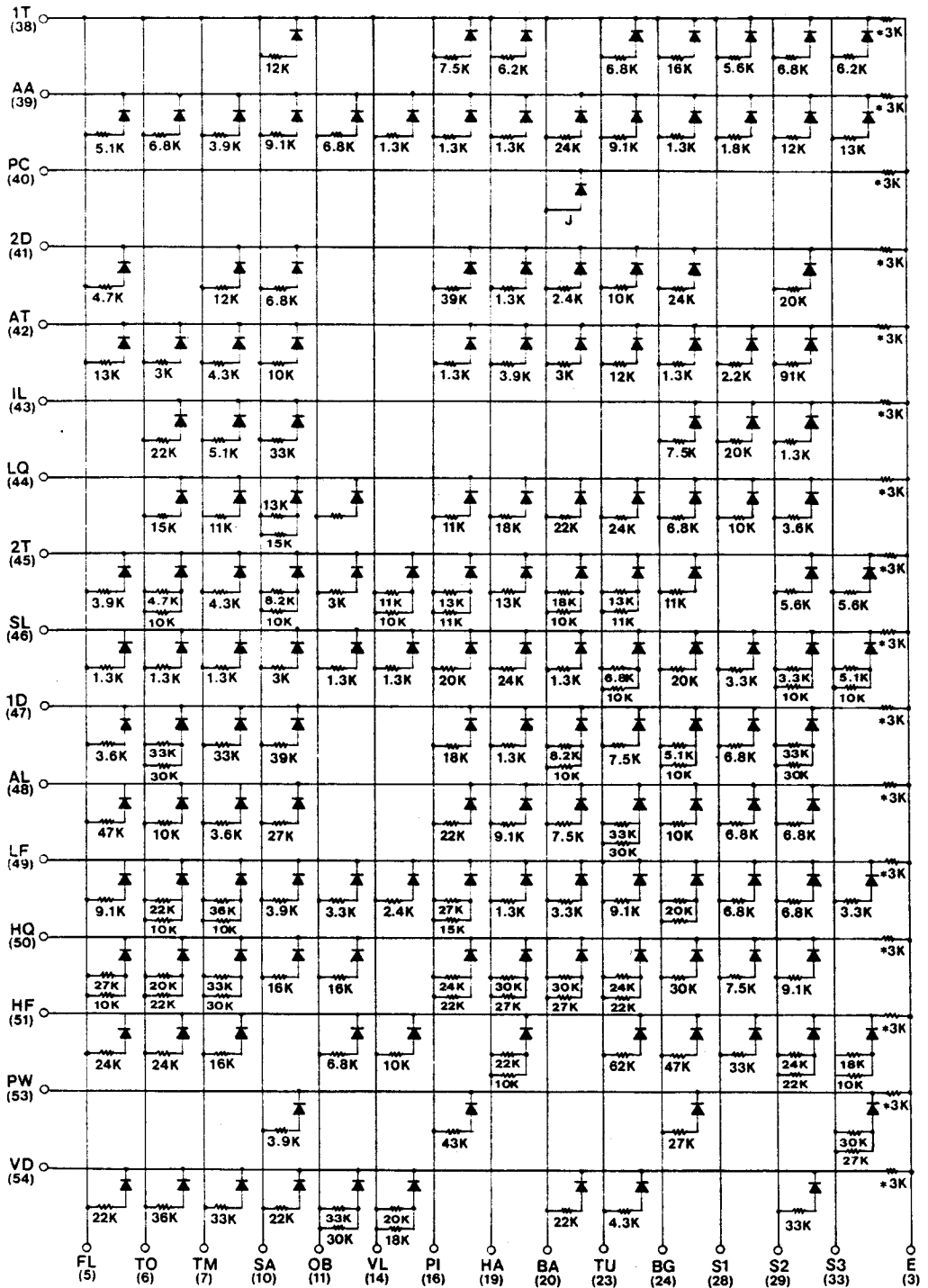

Note) Resistor =2% : Terminals VD~2T
 Resistor =5% : Terminals LQ~1T, VF~VM.
 Diode : 1S1555
 *Marked : Resistor =2%

SP1 Terminal Voltage Table

Output input	1T	AA	PC	2D	AT	IL	LQ	2T	SL	1D	AL	LF	HQ	HF	WA	PW	VD
FL	0	5.28	0	5.66	2.70	0	0	6.28	10.06	6.59	0.89	3.63	4.24	1.61	0	0	1.74
TO	0	4.25	0	0	7.11	1.79	2.35	7.01	10.06	2.32	3.31	4.30	3.25	1.59	0	0	1.12
TM	0	6.28	0	2.86	6.06	5.15	2.99	6.08	10.06	1.26	6.52	4.05	2.37	2.27	0	0	1.21
SA	2.94	3.53	0	4.20	3.33	1.17	4.33	5.79	7.27	1.01	1.42	6.29	2.28	0	0	6.24	1.74
OB	0	4.45	0	0	0	0	5.05	7.36	10.14	0	0	6.90	2.22	4.45	0	0	2.32
VL	0	2.73	0	0	0	0	0	5.18	10.15	0	0	7.96	0	3.36	0	0	3.56
PI	4.05	10.09	0	1.07	10.09	0	3.15	4.92	1.82	2.04	1.70	3.45	3.00	0	0	0.97	0
HA	4.70	10.11	0	10.12	6.10	0	2.12	2.73	1.57	10.12	3.51	10.12	2.50	4.36	0	0	0
BA	0	1.57	14.04	8.06	7.36	0	1.70	4.69	10.06	5.87	4.17	7.00	2.49	0	0	0	1.8
TU	4.25	3.63	0	3.32	2.87	0	1.56	4.87	6.05	4.16	2.31	3.66	3.03	0.66	0	0	6.00
BG	2.27	10.08	0	1.61	10.08	4.19	4.24	3.11	1.92	6.71	3.32	3.25	1.27	0.84	0	1.51	0
S1	4.87	8.94	0	0	8.25	1.92	3.38	0	6.87	4.39	4.43	4.44	4.13	1.22	0	0	0
S2	4.25	2.92	0	1.93	0.39	10.18	6.68	5.13	7.84	2.32	4.40	4.43	3.60	2.98	0	0	1.21
S3	4.71	2.53	0	0	0	0	0	4.98	6.77	0	0	6.90	0	4.51	0	2.54	0

± 10%

UNIT : VOLT

± 5%

*Please use the measuring instrument of the input impedance more than 100K Ω .

SP2 Circuit Diagram

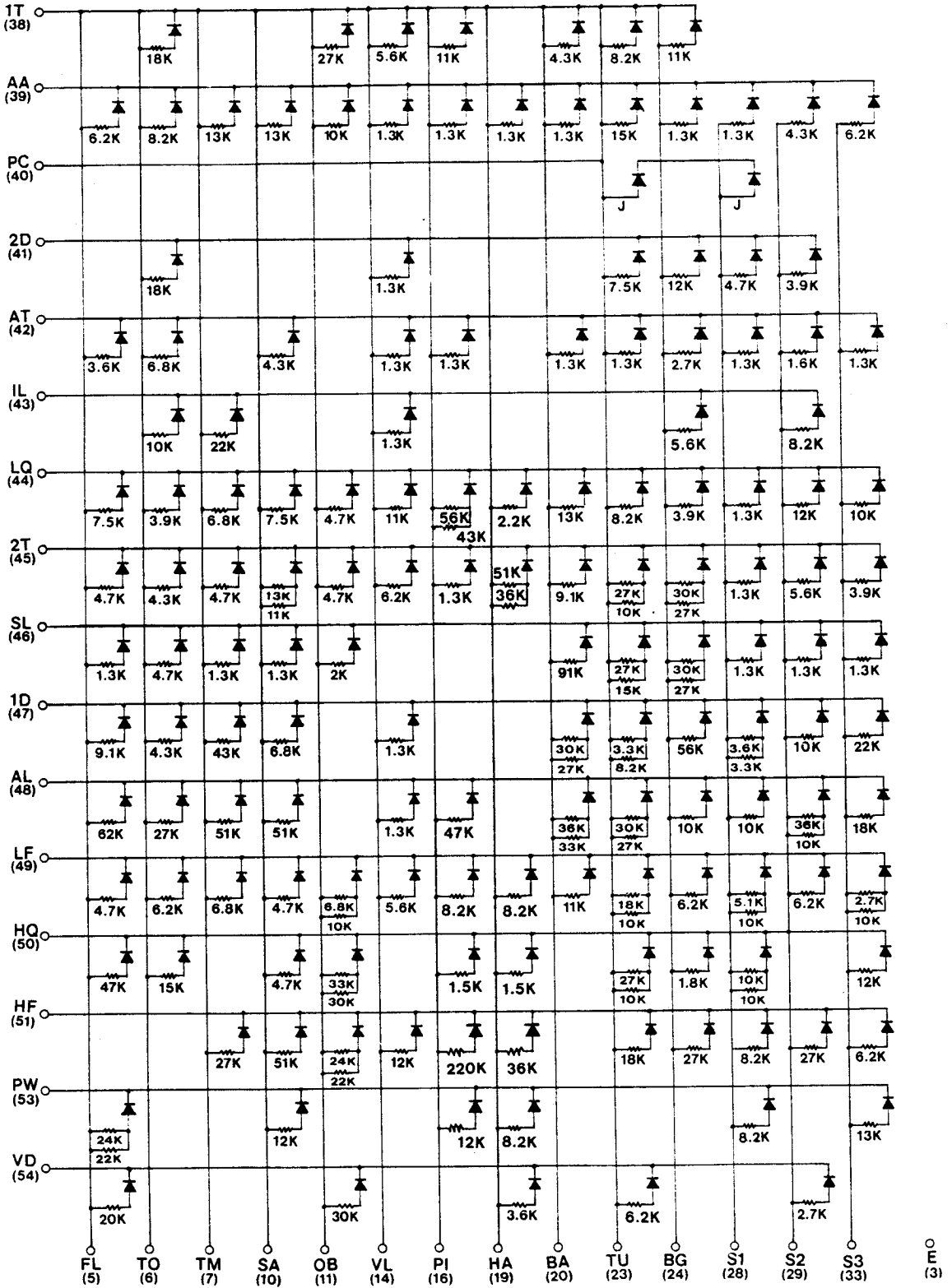

Note) Resistor : 2% : VD - 2T
 Resistor : 5% : LQ - 1T
 Diode : 1S1555
 J : Jumper wire

SP2 Terminal Voltage Table

Out in put put	1T	AA	PC	2D	AT	IL	LQ	2T	SL	1D	AL	LF	HQ	HF	WA	PW	VD
FL	0	4.53	0	0	6.58	0	4.03	5.66	10.14	3.53	0.65	5.62	0.89	0	0	2.98	1.905
TO	2.07	3.80	0	2.03	4.31	3.25	6.10	6.10	5.70	6.01	1.38	4.78	2.43	0	0	0	0
TM	0	2.55	0	0	0	1.73	4.27	5.68	10.17	0.91	0.82	4.44	0	1.47	0	0	0
SA	0	2.76	0	0	5.89	0	4.07	4.94	10.13	4.48	0.81	5.64	5.68	0.80	0	2.70	0
OB	1.38	3.19	0	0	0	0	5.67	5.70	8.76	0	0	6.09	2.32	3.04	0	0	1.32
VL	4.99	10.21	0	10.17	10.21	10.21	3.12	4.77	0	10.2	10.2	5.10	0	2.96	0	0	0
PI	2.21	9.84	0	0	9.82	0	5.30	9.84	0	0	0.85	3.79	9.46	0.19	0	2.77	0
HA	1.82	9.84	0	0	0	0	8.16	1.74	0	0	0	3.79	9.45	1.06	0	3.72	5.90
BA	5.90	10.19	0	0	10.19	0	2.54	3.58	0.42	2.54	2.14	3.09	0	0	0	0	0
TU	3.77	2.33	14.04	3.96	10.11	0	3.82	4.27	3.51	8.02	2.53	4.56	4.20	2.11	0	0	4.73
BG	2.97	10.15	0	2.90	7.65	0.74	6.32	2.54	2.53	0.73	3.33	4.72	9.12	1.48	0	0	0
S1	0	10.21	14.04	5.43	10.20	0	10.19	10.18	10.19	9.23	3.34	6.78	5.44	3.83	0	3.84	0
S2	0	5.93	0	6.37	9.19	3.79	2.95	4.94	10.12	3.30	4.03	4.70	0	1.46	0	0	7.63
S3	0	4.74	0	0	10.16	0	3.39	6.34	10.16	1.81	2.09	8.54	2.91	4.75	0	2.71	0

± 10%

± 5%

UNIT : VOLT

*Please use the measuring instrument of the input impedance more than 100KΩ.

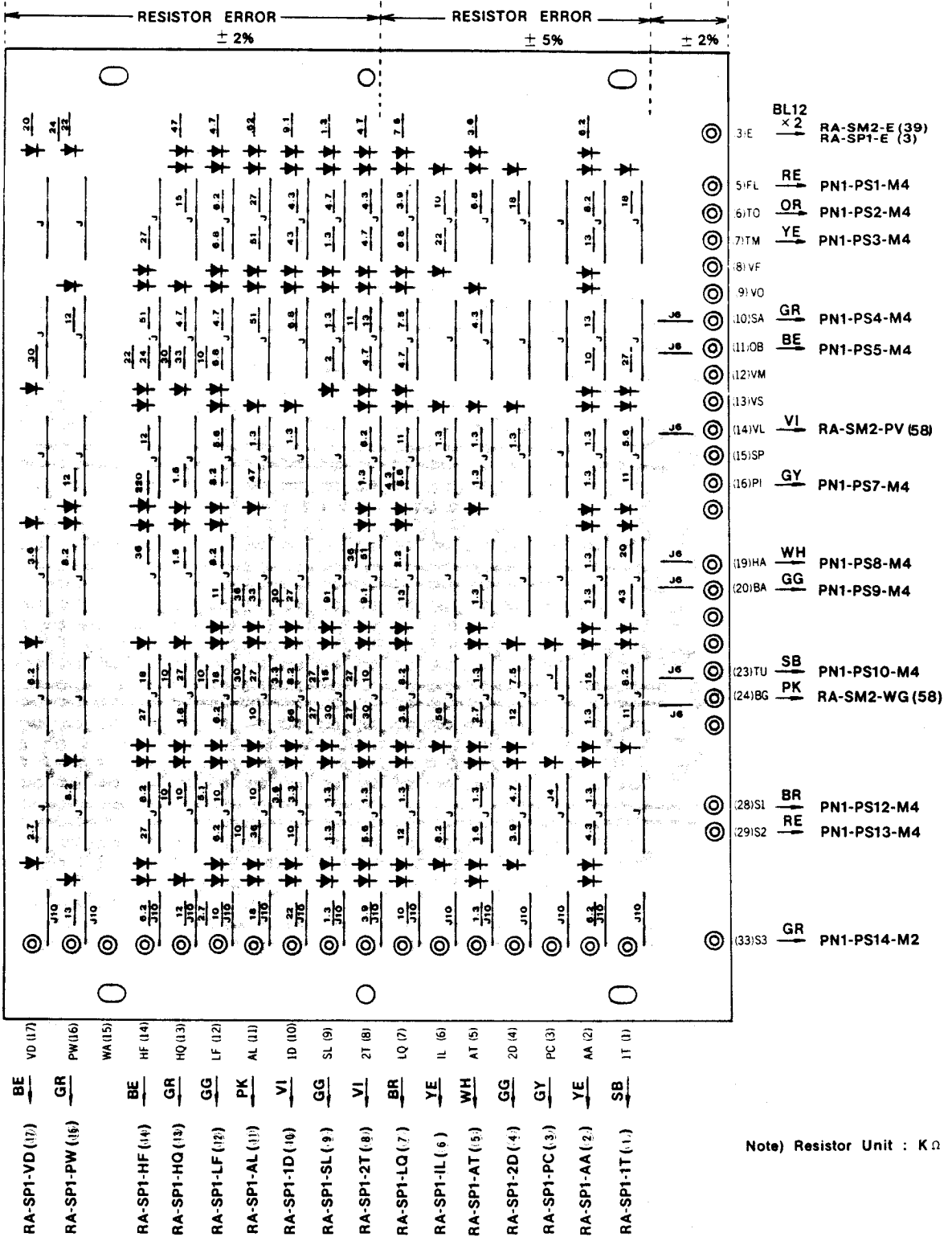

Note) Resistor Unit : K Ω

Power Supply Circuit Diagram

(S D)

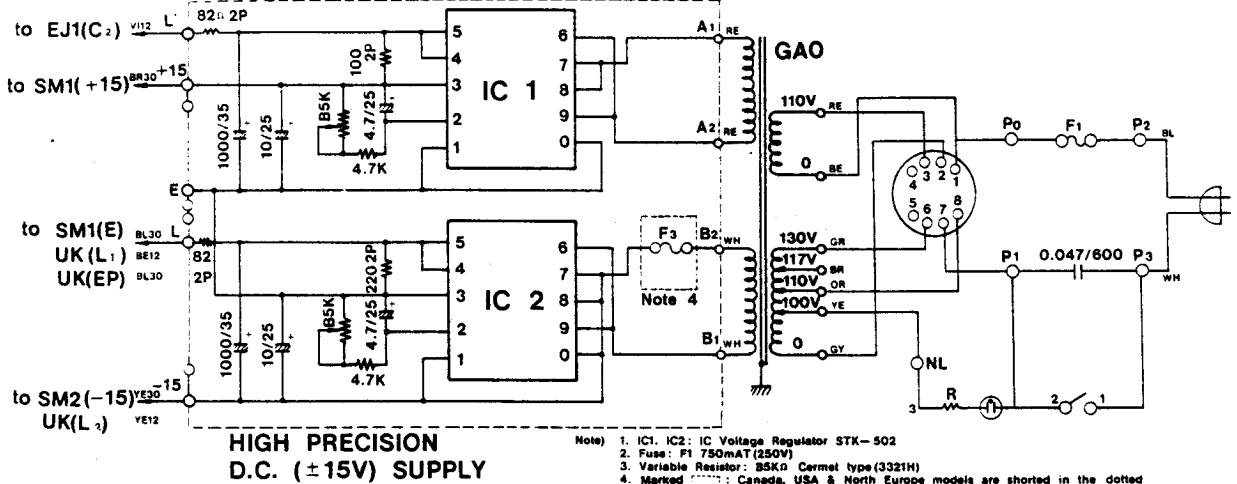

Australia model

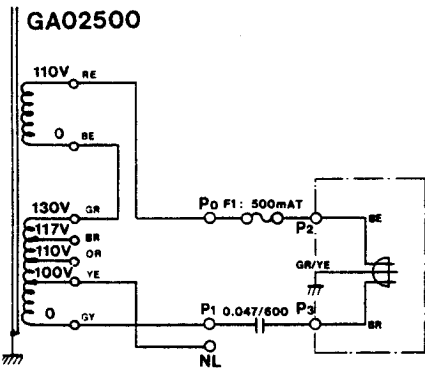

General model

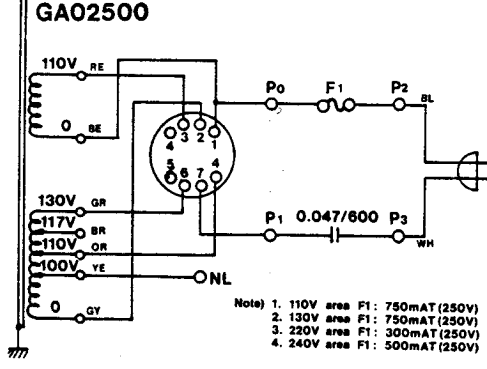

South Africa & Europe models

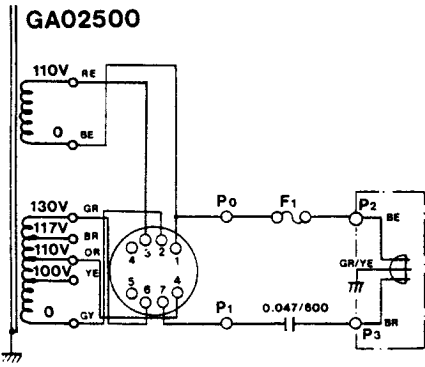

USA & Canada models

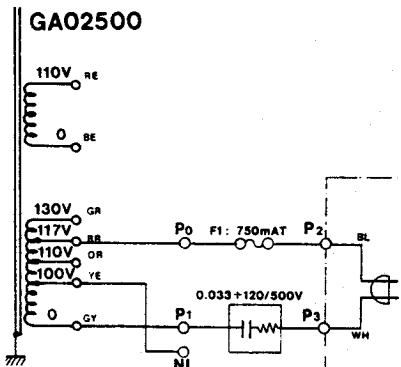

North Europe models

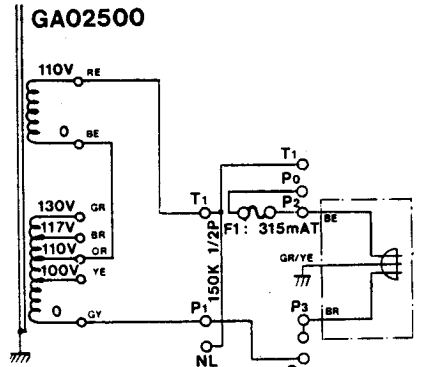

Panel 2, 3, & 4 Circuit Diagram

SY-2 (S/ # 1001 ~)

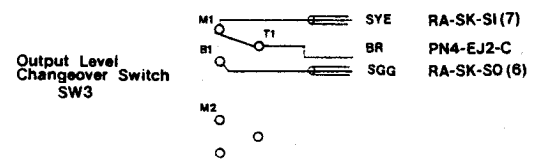
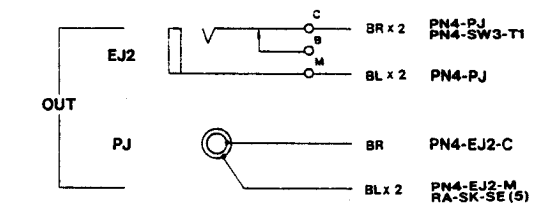
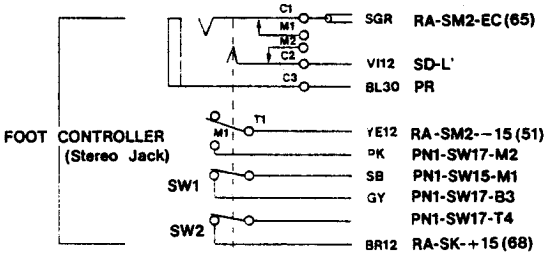
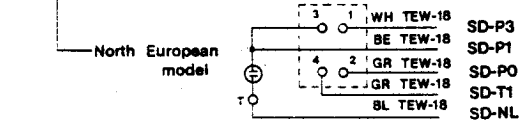
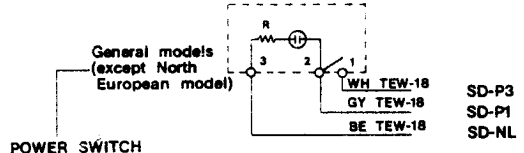
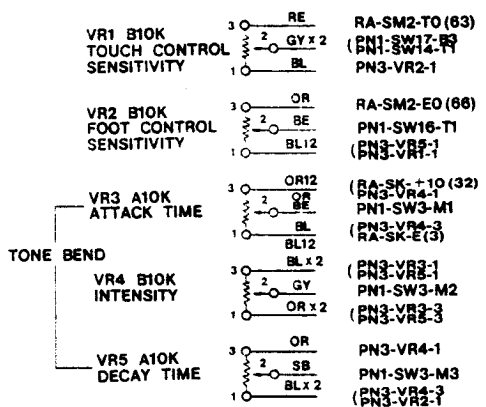
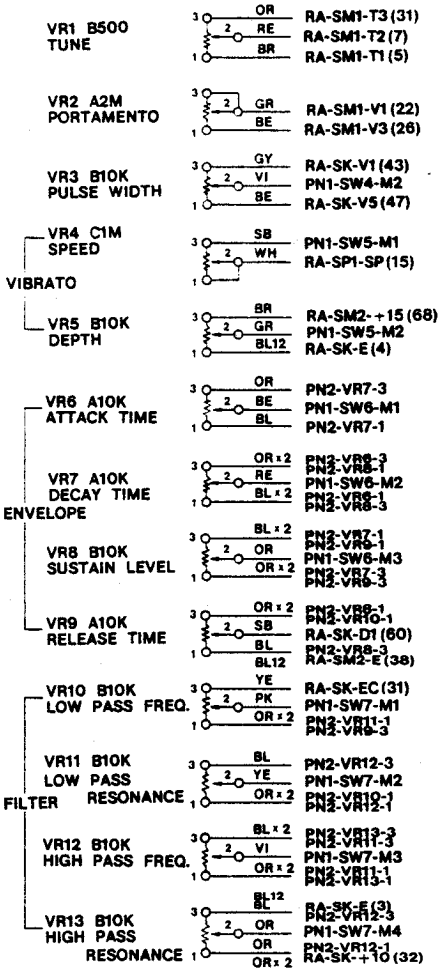

KEC-3488-4Y
 KEC-3489-4Y
 KEC-3490-4Y

Manual Key Board Switch Circuit Diagram

MK

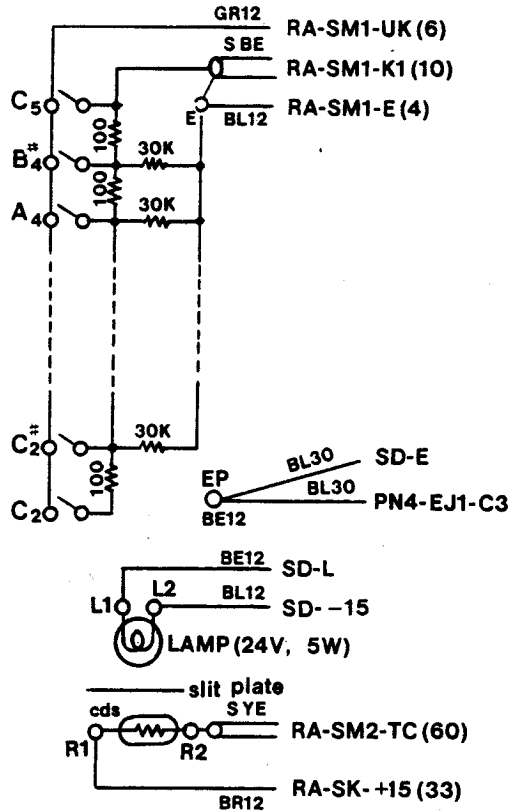

Key Board Voltage Table

NAME Key No.	C	C [#]	D	D [#]	E	F	F [#]	G	G [#]	A	A [#]	B
2	0.50	0.532	0.563	0.597	0.632	0.669	0.709	0.751	0.795	0.842	0.892	0.945
3	1.00	1.064	1.127	1.193	1.264	1.339	1.418	1.502	1.591	1.685	1.784	1.889
4	2.00	2.127	2.253	2.386	2.528	2.677	2.836	3.003	3.181	3.369	3.568	3.779
5	4.00	/	/	/	/	/	/	/	/	/	/	/

Note) Resistor: All Metal Film resistors $\pm 0.5\%$

New Parts Specification

1. LG00016 μ A741HC (FAIRCHILD)CONNECTION DIAGRAMS
(TOP VIEW)

8 LEAD METAL CAN

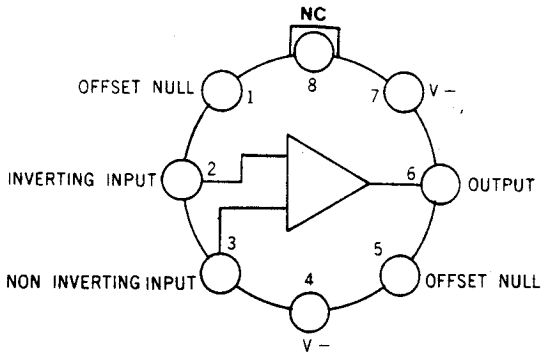

NOTE: PIN 4 CONNECTED TO CASE

Absolute Maximum Ratings

- Supply Voltage $\pm 18V$
- Internal Power Dissipation 500mW
- Differential Input Voltage $\pm 30V$
- DC Input Voltage $\pm 15V$
- Operating Temperature Range $0^{\circ}C$ to $+ 70^{\circ}C$

2. LG00036 CA3080 (RCA)

TOP VIEW

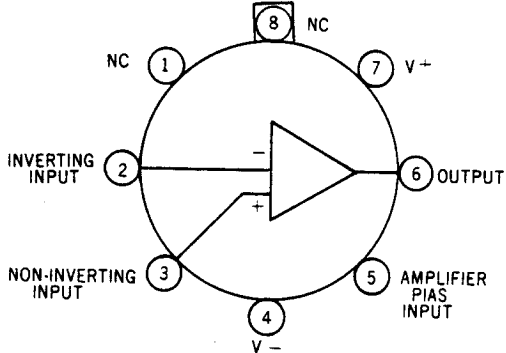

NOTE: PIN 8 IS INDICATED BY THE CASE INDEX TAB

Absolute Maximum Rating

- Supply Voltage $\pm 18V$
- Device Dissipation 125mW
- Differential Input Voltage $\pm 5V$
- DC Input Voltage $\pm 18V$
- Perating Tcmperature Range $0^{\circ}C$ to $+ 70^{\circ}C$

3. STK-502

(1) Absolute Maximum Ratings

Parameter	Symbol	Conditions	Max Ratings	Units
Average output current	I_o max.		1.0	A
Pulse output current	I_{op} max.	Pulse Width 6msec	3.0	A
Diode surge current	I_{surge}		30	A
Diode average rectification current	I_{ob} max.		0.5	A
Input max. DC voltage	V_{bc} max.	Voltage control part	34	V
Input max. AC voltage	V_{ac} max.	Rectificated part	30	V
IC Bass Operating Temperature	T_c		85	°C
Storage Temperature Range	T_{stg}		-30 ~ +100	°C

(2) Operating Characteristics (Temperature=25°C)

Parameter	Symbol	Conditions	Min	Normal	Max.	Units
Output voltage	V_o	$V_{oc}=22V, I_o=1.0A$	17.7	18.0	18.3	V
Output impedance	R_o	$V_{oc}=22V, I_o=0.1\sim 1.0A$		15		m
Stability coefficient	S	$V_{oc}=22\sim 30V, I_o=1.0A$		0.8		mV/V _{oc}
Temperature coefficient	α_T	$T_c -10^\circ C \sim +85^\circ C$ $V_{oc} 22V, I_o=1.0A$	-3	± 1.0	+3	mV/°C
Ripple voltage	V_{rp}	$C_{in}=1000\mu F$ $V_{oc}=22V, I_o=0.3A$			1.5	mVrms

(3) Transistor

ic15370 2SC1537p

Please use 2SC828 of the Substitutive transistor.

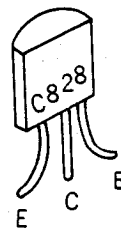
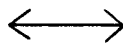
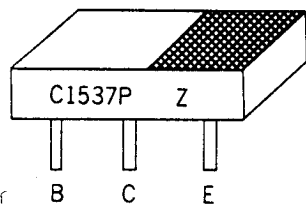

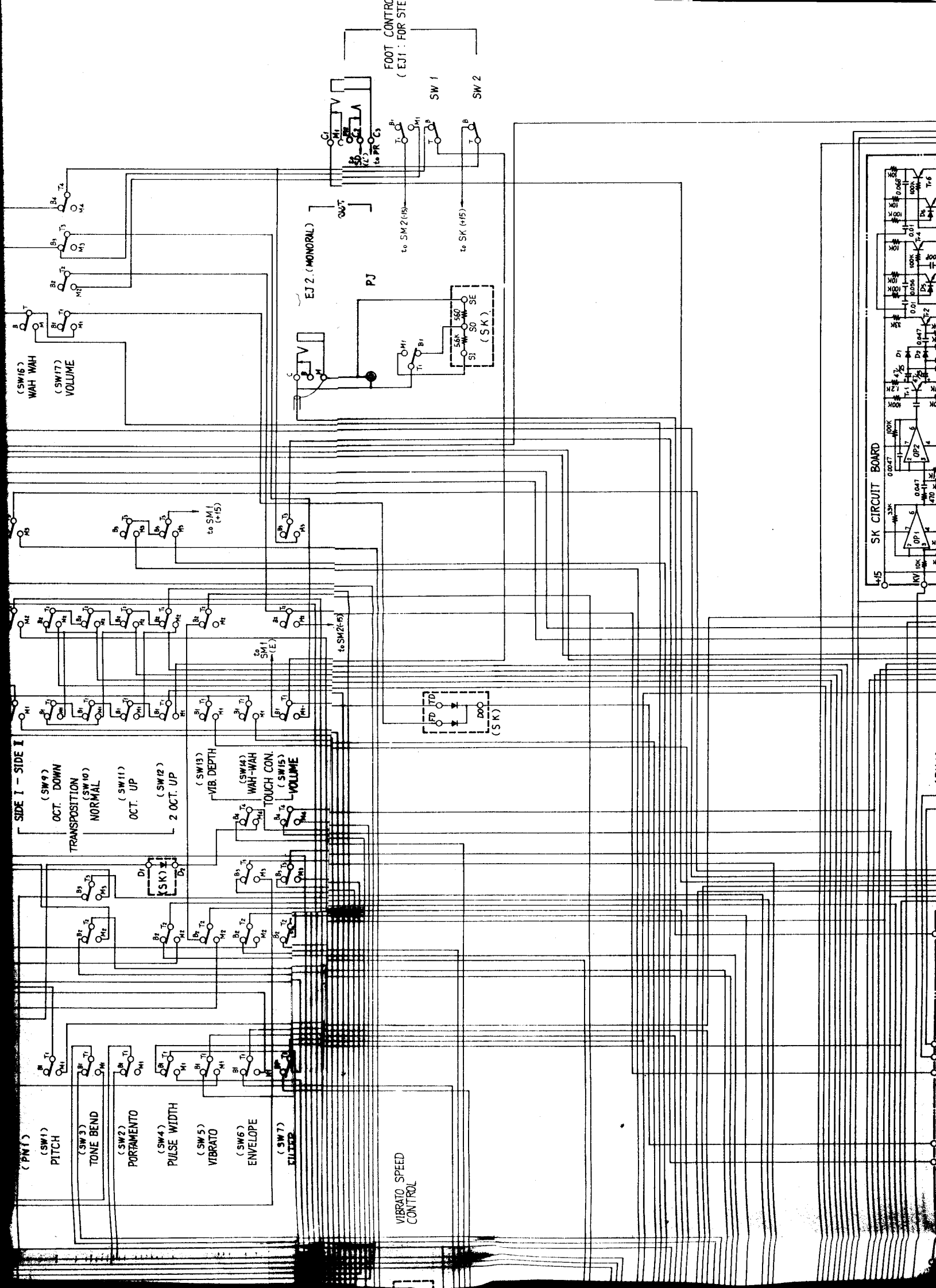

SY-2 Overall Circuit Diagram

SY-2 (S/ # 1001

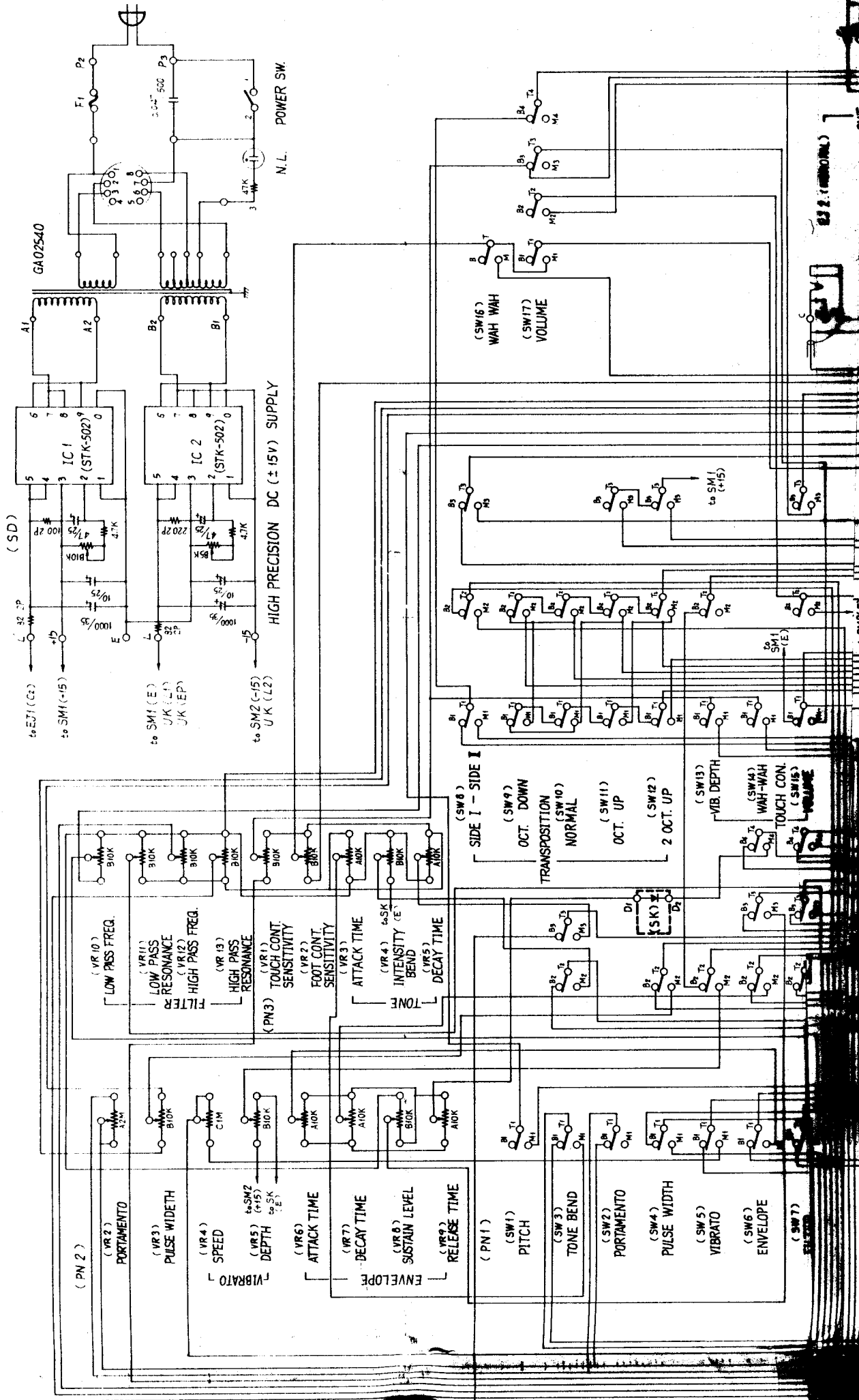

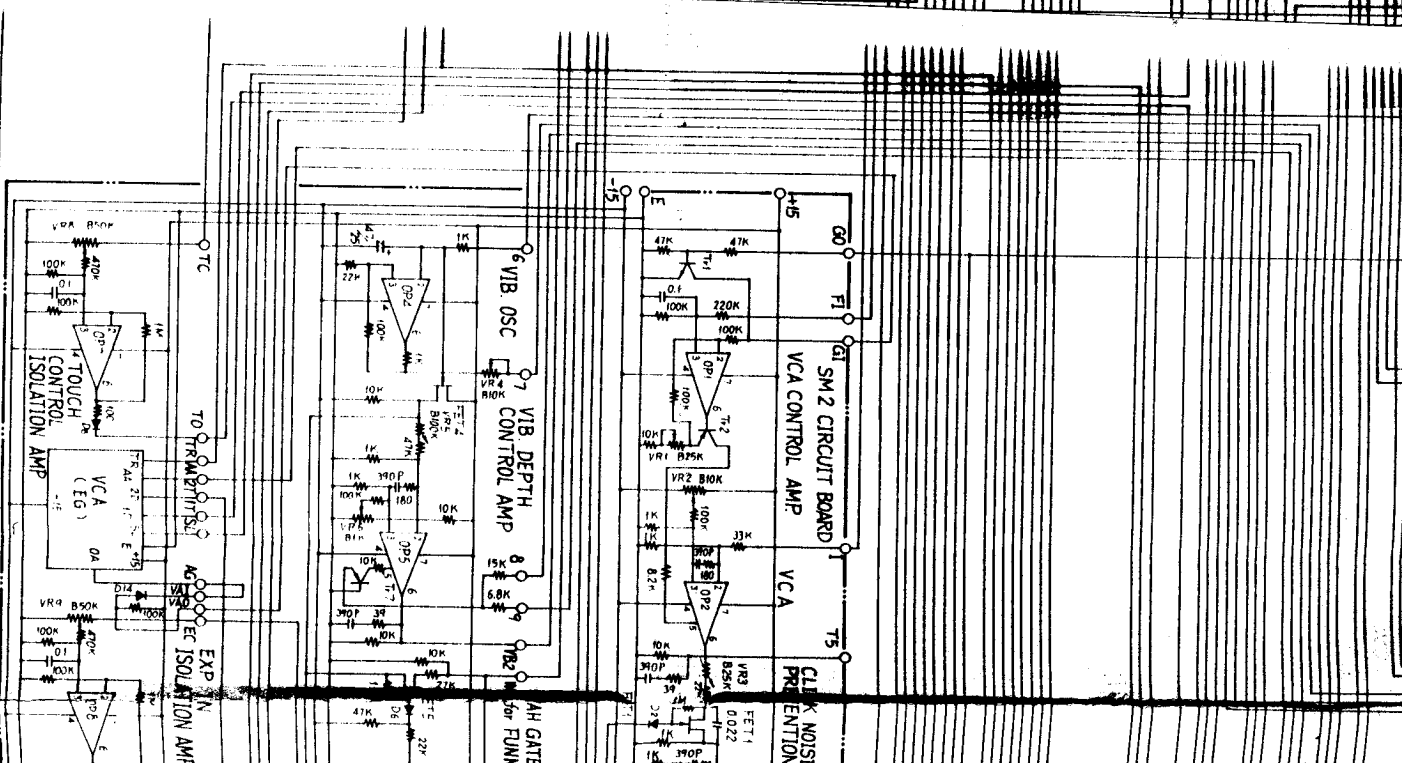
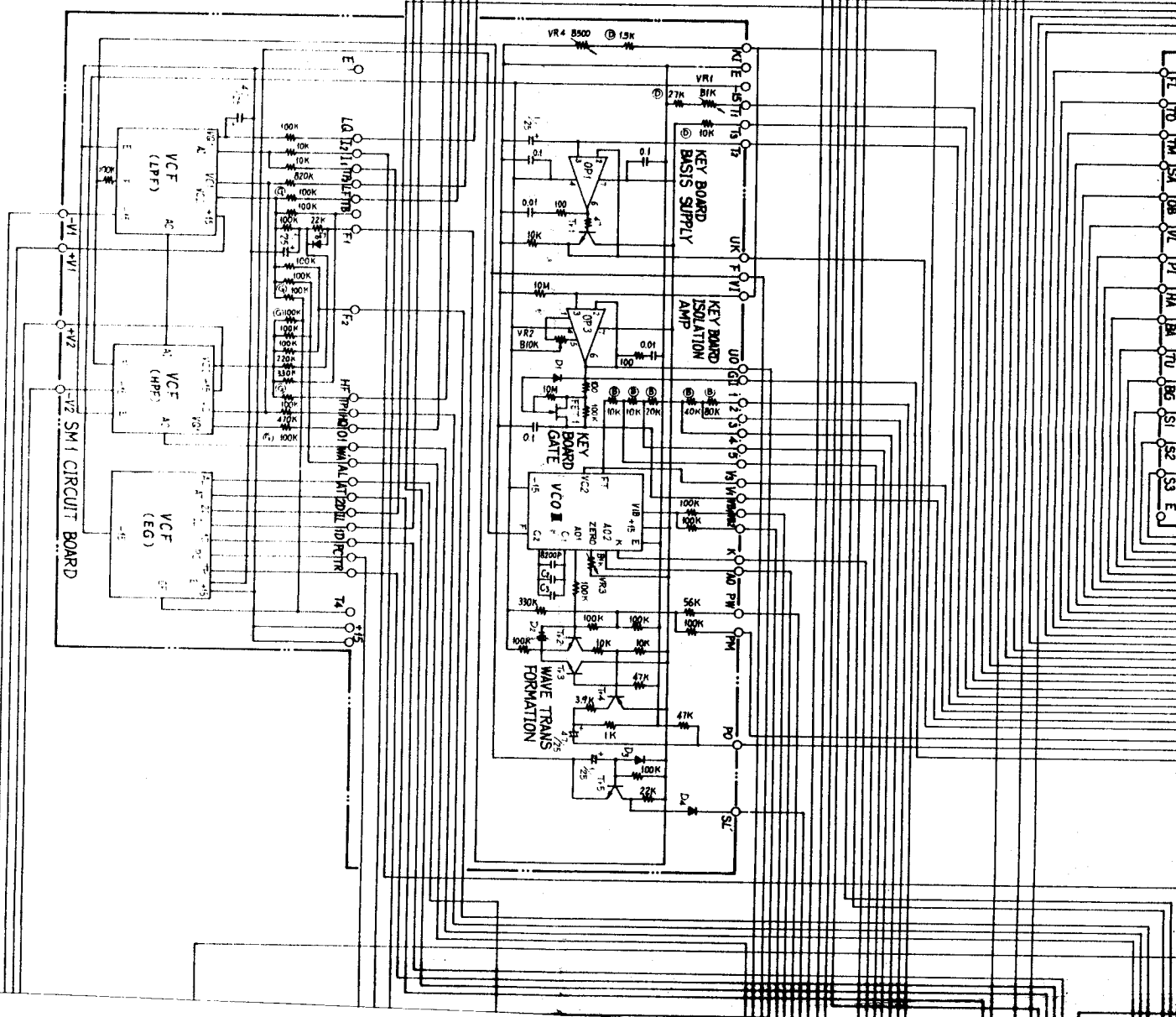

SP 2 CIRCUIT DIAGRAM
VOLTAGE MATRIX FOR THE SIDE I PRESET TONE

VD	30K	20K	10K	5K	2.5K	1.5K	1K	500	250	150	100	50	25	15	10	5	2.5	1.5	1	500	250	150	100	50	25	15	10	5	2.5	1.5	1											
FL	20K	10K	5K	2.5K	1.5K	1K	500	250	150	100	50	25	15	10	5	2.5	1.5	1	500	250	150	100	50	25	15	10	5	2.5	1.5	1	500	250	150	100	50	25	15	10	5	2.5	1.5	1
TO	10K	5K	2.5K	1.5K	1K	500	250	150	100	50	25	15	10	5	2.5	1.5	1	500	250	150	100	50	25	15	10	5	2.5	1.5	1	500	250	150	100	50	25	15	10	5	2.5	1.5	1	
TM	5K	2.5K	1.5K	1K	500	250	150	100	50	25	15	10	5	2.5	1.5	1	500	250	150	100	50	25	15	10	5	2.5	1.5	1	500	250	150	100	50	25	15	10	5	2.5	1.5	1		
SA	2.5K	1.5K	1K	500	250	150	100	50	25	15	10	5	2.5	1.5	1	500	250	150	100	50	25	15	10	5	2.5	1.5	1	500	250	150	100	50	25	15	10	5	2.5	1.5	1			
DB	1.5K	1K	500	250	150	100	50	25	15	10	5	2.5	1.5	1	500	250	150	100	50	25	15	10	5	2.5	1.5	1	500	250	150	100	50	25	15	10	5	2.5	1.5	1				
UL	1K	500	250	150	100	50	25	15	10	5	2.5	1.5	1	500	250	150	100	50	25	15	10	5	2.5	1.5	1	500	250	150	100	50	25	15	10	5	2.5	1.5	1					
PI	500	250	150	100	50	25	15	10	5	2.5	1.5	1	500	250	150	100	50	25	15	10	5	2.5	1.5	1	500	250	150	100	50	25	15	10	5	2.5	1.5	1						
HA	250	150	100	50	25	15	10	5	2.5	1.5	1	500	250	150	100	50	25	15	10	5	2.5	1.5	1	500	250	150	100	50	25	15	10	5	2.5	1.5	1							
BA	150	100	50	25	15	10	5	2.5	1.5	1	500	250	150	100	50	25	15	10	5	2.5	1.5	1	500	250	150	100	50	25	15	10	5	2.5	1.5	1								
TU	100	50	25	15	10	5	2.5	1.5	1	500	250	150	100	50	25	15	10	5	2.5	1.5	1	500	250	150	100	50	25	15	10	5	2.5	1.5	1									
BG	50	25	15	10	5	2.5	1.5	1	500	250	150	100	50	25	15	10	5	2.5	1.5	1	500	250	150	100	50	25	15	10	5	2.5	1.5	1										
SI	25	15	10	5	2.5	1.5	1	500	250	150	100	50	25	15	10	5	2.5	1.5	1	500	250	150	100	50	25	15	10	5	2.5	1.5	1											
S2	15	10	5	2.5	1.5	1	500	250	150	100	50	25	15	10	5	2.5	1.5	1	500	250	150	100	50	25	15	10	5	2.5	1.5	1												
S3	10	5	2.5	1.5	1	500	250	150	100	50	25	15	10	5	2.5	1.5	1	500	250	150	100	50	25	15	10	5	2.5	1.5	1													
E	5	2.5	1.5	1	500	250	150	100	50	25	15	10	5	2.5	1.5	1	500	250	150	100	50	25	15	10	5	2.5	1.5	1														

- (P3 8) HARPIS - MANDIAN
- (P3 9) CHIND - GUITAR
- (P3 10) CONTRA - PIZZICATO
- (P3 11) BASS - BASS
- (P3 12) TUBA - SOUSA
- (P3 13) PHONE
- (P3 14) BASS - WAH
- (P3 15) GUITAR - GUITAR
- (P3 16) PUNNY - DRAKE
- (S13) TRIM - GLOWL
- (P5 14) DO FILE - REED

